

## Product Overview

NSPGD1 series are calibrated gauge pressure sensor which combines state-of-art MEMS sensor technology and CMOS mix-signal processing technology to produce an amplified, fully conditioned, multi-order pressure and temperature compensated sensor in a Double In-line Package (DIP) with tube port. NSPGD1 series pressure sensor is target for household electric appliances and the small kitchen and bathroom home-appliances. Combining the pressure sensor with a signal conditioning ASIC in a single package simplifies the use of advanced silicon micromachined pressure sensors. The pressure sensor can be mounted directly to a standard printed circuit board and an amplified, high-level, calibrated pressure signal can be acquired from the digital interface or analog/frequency output. This eliminates the need for additional circuitry, such as a compensation network or micro-controller containing a custom correction algorithm. NSPGD1 series are designed for operating pressure ranges of -10kPa ~ 10kPa Gauge, very suitable for household electronics such as washing machine and dishwasher.

## Key Features

- Custom range -10kPa~10kPa
- High accuracy
  - Total error band initially better than  $\pm 1\%$ F.S.
  - Full life accuracy better than  $\pm 2.5\%$ F.S.
- Temperature range 0~70°C
- Ratio-metric/Absolute analog output
- 24bit I<sup>2</sup>C output
- Frequency output
- Front side of the chip enters the gas, not easing to block
- Waterproof and moisture-proof treatment inside
- RoHS & REACH Compliance

## Applications

- Washing machine
- Dishwasher, water purifier
- Air bed, massage chair
- Smart sphygmomanometer, oxygen generator
- Industrial control
- IoT pressure detection

## Device Information

Part Number	Package	Body Size
NSPGD1	DIP8	10.4mm*10.4mm

## Outline

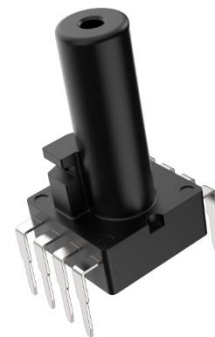

**INDEX**

1. PIN CONFIGURATION AND FUNCTIONS .....	3
2. ABSOLUTE MAXIMUM RATINGS .....	5
3. ESD RATINGS .....	5
4. RECOMMENDED OPERATING CONDITIONS.....	5
5. SPECIFICATIONS.....	6
5.1. ELECTRICAL CHARACTERISTICS.....	6
5.2. I <sup>2</sup> C TIMING DIAGRAM.....	7
5.3. I <sup>2</sup> C ELECTRICAL CHARACTERISTICS .....	7
6. FUNCTION DESCRIPTION .....	8
6.1. OVERVIEW.....	8
6.1. ANALOG OUTPUT TRANSFER FUNCTION .....	8
6.2. DIGITAL OUTPUT TRANSFER FUNCTION .....	9
6.3. FREQUENCY OUTPUT TRANSFER FUNCTION .....	10
6.4. I <sup>2</sup> C INTERFACE .....	10
7. TYPICAL APPLICATION.....	12
7.1. APPLICATION CIRCUIT.....	12
8. PACKAGE INFORMATION.....	14
8.1. PACKAGE SIZE.....	14
8.2. RECOMMENDED FOOTPRINT .....	14
9. ORDER INFORMATION .....	15
10. IDENTIFICATION CODE .....	16
11. SOLDERING PARAMETERS .....	16
12. PACKING INFORMATION .....	17
13. REVISION HISTORY .....	18
NOTES: .....	19

### 1. Pin Configuration and Functions

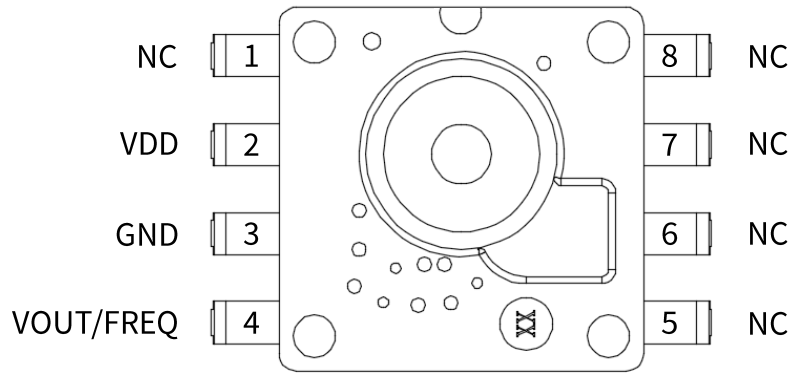

Figure 1.1 NSPGD1 Analog/ Frequency Output Pin Definition (Top View)

Table 1.1 Analog/ Frequency Output Pin Description

Pin NO.	Pin Name	Description
1	NC	NC
2	VDD	Power Supply
3	GND	Ground
4	VOUT / FREQ	Analog Output / Frequency Output
5	NC	NC
6	NC	NC
7	NC	NC
8	NC	NC

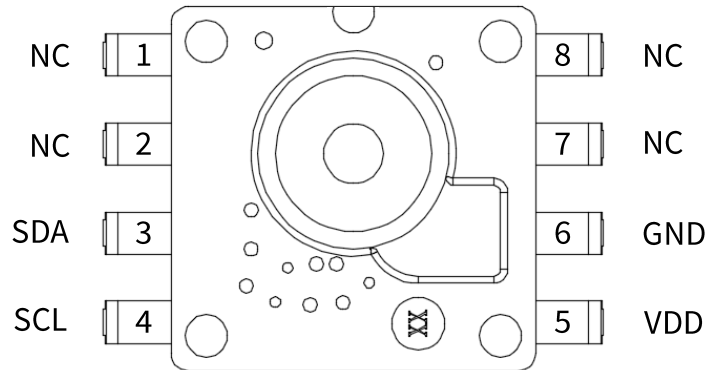

Figure 1.2 NSPGD1 Digital Output Pin Definition (Top View)

Table 1.2 Digital Output Pin Description

<i>Pin NO.</i>	<i>Pin Name</i>	<i>Description</i>
1	NC	NC
2	NC	NC
3	SDA	I <sup>2</sup> C Data Signal
4	SCL	I <sup>2</sup> C Clock Signal
5	VDD	Power Supply
6	GND	Ground
7	NC	NC
8	NC	NC

## 2. Absolute Maximum Ratings

Parameters	Symbol	Min	Typ	Max	Unit	Comments
Supply Voltage	VDD <sub>max</sub>	-0.3		6.5	V	
Analog Output Current Limit				25	mA	
Analog Pin Voltage		-0.3		VDD+0.3	V	
Proof Pressure	P <sub>proof</sub>	30			kPa	
Burst Pressure	P <sub>burst</sub>	50			kPa	
Storage Temperature	T <sub>stg</sub>	-40		105	°C	

## 3. ESD Ratings

Ratings		Value	Unit
Electrostatic Discharge	Human body model (HBM), per AEC-Q100-002-RevE	±2	kV
	Charged device model (CDM), per AEC-Q100-011-RevD	±500	V
	Latch up (LU), per JESD78D	±100	mA

## 4. Recommended Operating Conditions

Parameters	Symbol	Min	Typ	Max	Unit	Comments
Supply Voltage	VDD	3	3.3	3.6	V	Analog output
		4.5	5	5.5		Digital output
		4.8	5	5.2		Frequency output
Operating Pressure	P <sub>amb</sub>	-10		10	kPaG	
Operating Pressure Range	P <sub>range</sub>	2		20	kPa	P <sub>max</sub> - P <sub>min</sub>
Operating Temperature	T <sub>opr</sub>	0		70	°C	

## 5. Specifications

### 5.1. Electrical Characteristics

Parameters	Symbol	Min	Typ	Max	Unit	Comments
Operating Current	$I_{avdd}$	1.8	2.5	3	mA	Analog/ Frequency output
			0.3	30	uA	Standby mode in digital output
Accuracy <sup>1,2,3</sup>	ACC	-1%		1%	%FS	Initially accuracy
		-2.5%		2.5%	%FS	Full life accuracy
ADC Resolution	RES <sub>RAW</sub>		24		Bits	
PSRR	PSRR	90	120		dB	
DAC Resolution			12		Bits	
Output Load Resistance	R <sub>load</sub>	1			kOhm	Analog output
Output Load Capacitance	C <sub>load</sub>			15	nF	Analog output
Response Time	T <sub>RESP</sub>		4		ms	
EEPROM Data Retention	T <sub>live</sub>	10			years	@125°C

- Accuracy includes non-linearity, temperature, pressure hysteresis, temperature hysteresis.
- Full life accuracy based on the part number NSPGD1F002RT02 500 hour HTOL, LTOL, HTSL, THB and TCT testing.
- For pressure accuracy of different part number, please refer to complete part number list at chapter 9. Unless otherwise specified, the accuracy is based on typical operating voltage.
- The ratiometric analog output also include  $\pm 0.5\%$  ratiometric error. The ratiometric error is defined as the difference between the ratio that VDD changed and the ratio that VOUT changed. Ratiometric signal error is not included in the overall accuracy. Absolute analog output and  $\rho C$  output are not applicable.

### 5.2. I<sup>2</sup>C Timing Diagram

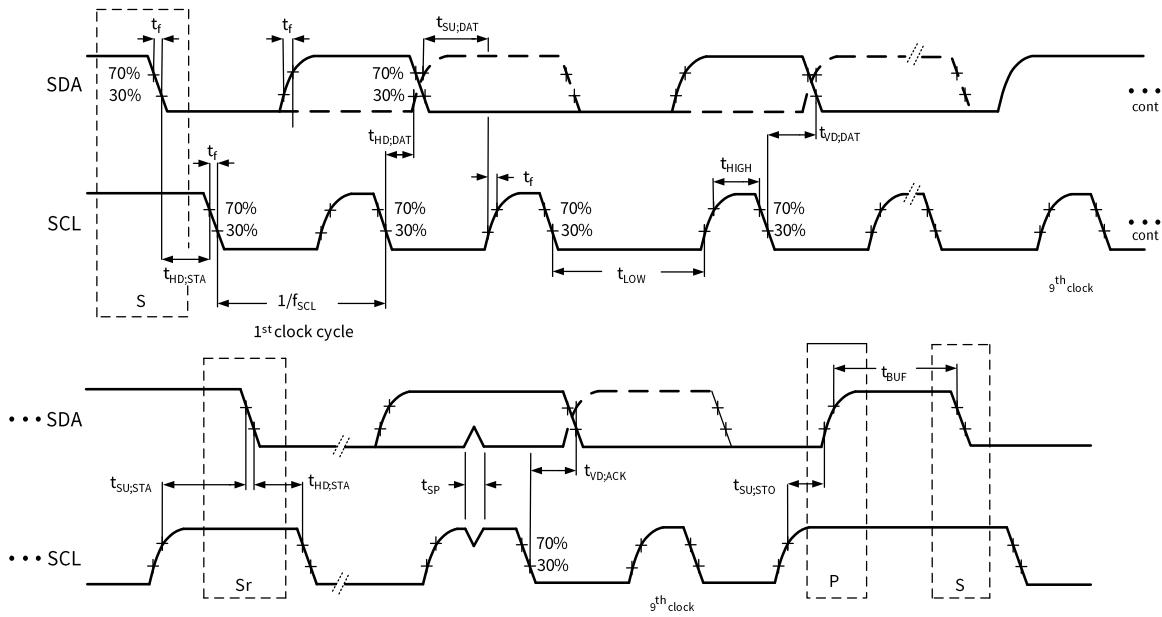

Figure 5.1 I<sup>2</sup>C Timing Diagram

### 5.3. I<sup>2</sup>C Electrical Characteristics

Parameters	Symbol	Min	Typ	Max	Unit	Comments
Clock Frequency	$f_{scl}$			400	kHz	
SCL Low Pulse	$t_{LOW}$	1.3			$\mu$ s	
SCL High Pulse	$t_{HIGH}$	0.6			$\mu$ s	
SDA Setup Time	$t_{SU,DAT}$	0.1			$\mu$ s	
SDA Hold Time	$t_{HD,DAT}$	0.0			$\mu$ s	
Setup Time for a Repeated Start Condition	$t_{SU,STA}$	0.6			$\mu$ s	
Hold Time for a Start Condition	$t_{HD,STA}$	0.6			$\mu$ s	
Setup Time for a Stop Condition	$t_{SU,STO}$	0.6			$\mu$ s	
Time before a New Transmission Can Start	$t_{BUF}$	1.3			$\mu$ s	

## 6. Function Description

### 6.1. Overview

NSPGD1 uses a MEMS piezoresistive differential pressure sensor element as a pressure sensitive component that provide an original signal output that is proportional to ambient pressure. The built-in conditioning IC drives the sensitive component and amplifies, temperature compensates, and linearizes the original signal to output a signal that is linear with the applied pressure.

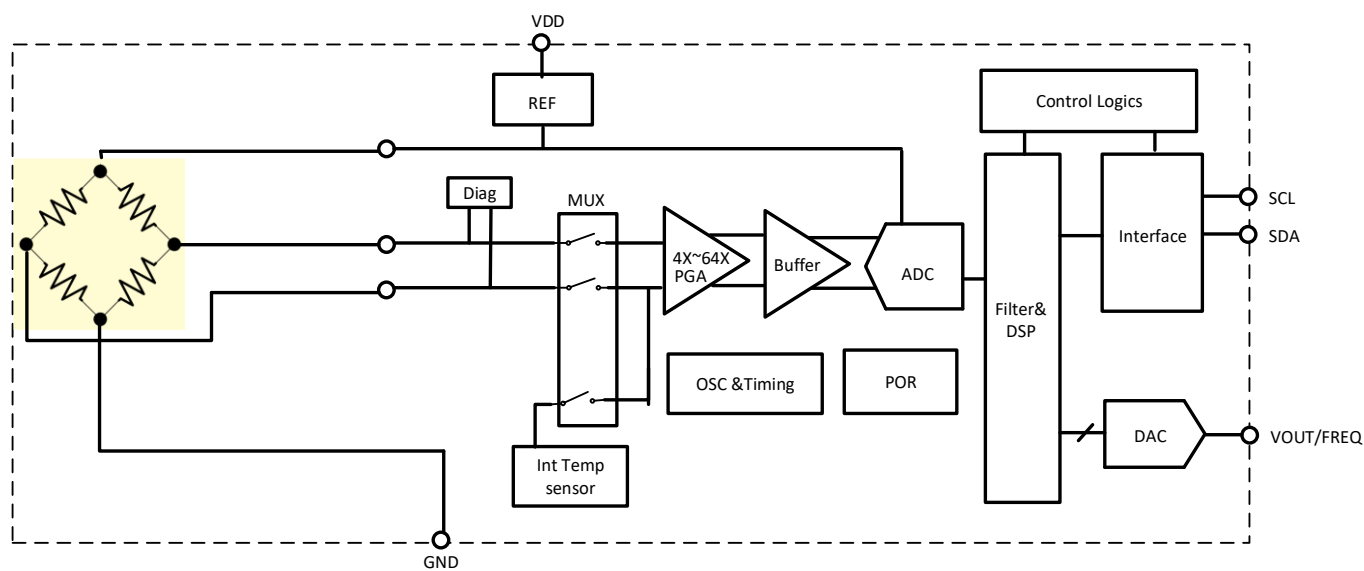

Figure 6.1 Product Function Block Diagram

### 6.1. Analog Output Transfer Function

$$VOUT = (A \times P + B) \times 5 \text{ @absolute analog output, VDD=5V}$$

$$VOUT = (A \times P + B) \times 3.3 \text{ @absolute analog output, VDD=3.3V}$$

$$VOUT = (A \times P + B) \times VDD \text{ @ratiometric analog output}$$

Note:

VOUT is the analog output, unit is V.

P is the pressure value, gauge pressure, unit is kPa/mmH2O.

Table 6.1 Analog Output Transfer Function Coefficient

Product NO.	Pressure Range		Output Range		Gain and Offset	
	$P_L$	$P_H$	$O_L$	$O_H$	A	B
NSPGD1F002RT02	0kPa	2kPa	0.1*VDD	0.9*VDD	0.4	0.1



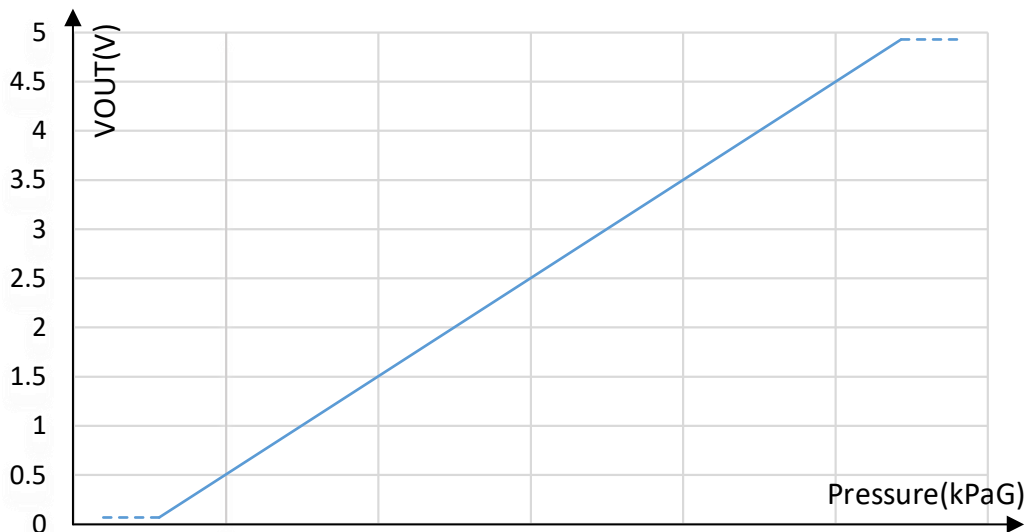

Figure 6.2 Analog Output Transfer Function

### 6.2. Digital Output Transfer Function

$$\text{Code} = (A \times P + B) \times 8388607$$

Code is the register 0x06~0x08 value.

P is the pressure value, gauge pressure, unit is kPa/mmH2O.

Table 6.2 Digital Output Transfer Function Coefficient

Product NO.	Pressure Range		Output Range		Gain and Offset	
	P <sub>L</sub>	P <sub>H</sub>	O <sub>L</sub>	O <sub>H</sub>	A	B
NSPGD1F006DT04	0kPa	6kPa	838861	7549746	0.13333	0.1

Register Map:

Address	Bit Address	Description	Default	Description
0x30	7 - 4	Reserve	4'b0000	Write with 0x0A to start a conversion, automatically come back to 0x02 after conversion ends.
	3	Sco	1'b0	
	2 - 0	Measurement_ctrl<2:0>	3'b000	
0x06	7 - 0	PDATA<23:16>	0x00	Output Pressure Data. Code = Data0x06*2 <sup>16</sup> + Data0x07*2 <sup>8</sup> + Data0x08;
0x07	7 - 0	PDATA<15:8>	0x00	
0x08	7 - 0	PDATA<7:0>	0x00	

For example:

If the value of the registers 0x06、0x07、0x08 are 0x3F, 0xFF, 0xFF, according to NSPGD1F006DT04 transfer function, Code = 4194303, P(kPa) = (4194303/8388607-B)/A, and finally get the value of pressure about 3kPa.

### 6.3. Frequency Output Transfer Function

$$FREQ = (A \times P + B) \times F.S.$$

Note:

- 1) FREQ is the frequency output, unit is kHz.
- 2) P is the pressure value, gauge pressure, unit is kPa/mmH2O.
- 3) F.S. is the full scale of frequency output. The chip can be configured with four full-scale frequencies, which are 250kHz, 125kHz, 61.5kHz, and 31.25kHz.

Table 6.3 Frequency Output Transfer Function Coefficient

Product NO.	Pressure Range		Output Range		Gain and Offset		Full Scale
	$P_L$	$P_H$	$O_L$	$O_H$	A	B	F.S.
NSPGD1F004FT12	0mmH2O	350mmH2O	3.125kHz	28.125kHz	0.002285714	0.1	31.25kHz

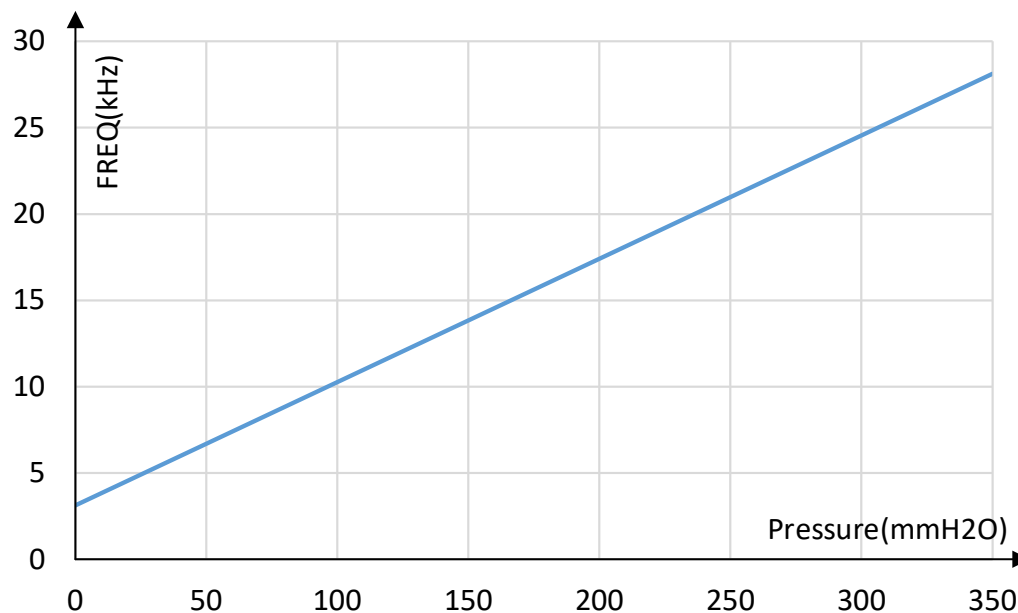

Figure 6.3 Frequency Output Transfer Function

### 6.4. I<sup>2</sup>C Interface

I<sup>2</sup>C bus uses SCL and SDA as signal lines. Both lines are connected to VDD externally via pull-up resistors so that they are pulled high when the bus is free. The I<sup>2</sup>C device address of NSPGD1 is shown below.

Table 6.4 I<sup>2</sup>C Address

A7	A6	A5	A4	A3	A2	A1	W/R
1	1	1	1	1	1	1	0/1

The I<sup>2</sup>C interface protocol has special bus signal conditions. Start (S), stop (P) and binary data conditions are shown below. At start condition, SCL is high and SDA has a falling edge. Then the slave address is sent. After the 7 address bits, the direction control bit R/W selects the read or write operation. When a slave device recognizes that it is being addressed, it should acknowledge by pulling SDA low in the ninth SCL (ACK) cycle.

At stop condition, SCL is also high, but SDA has a rising edge. Data must be held stable at SDA when SCL is high. Data can change value at SDA only when SCL is low.

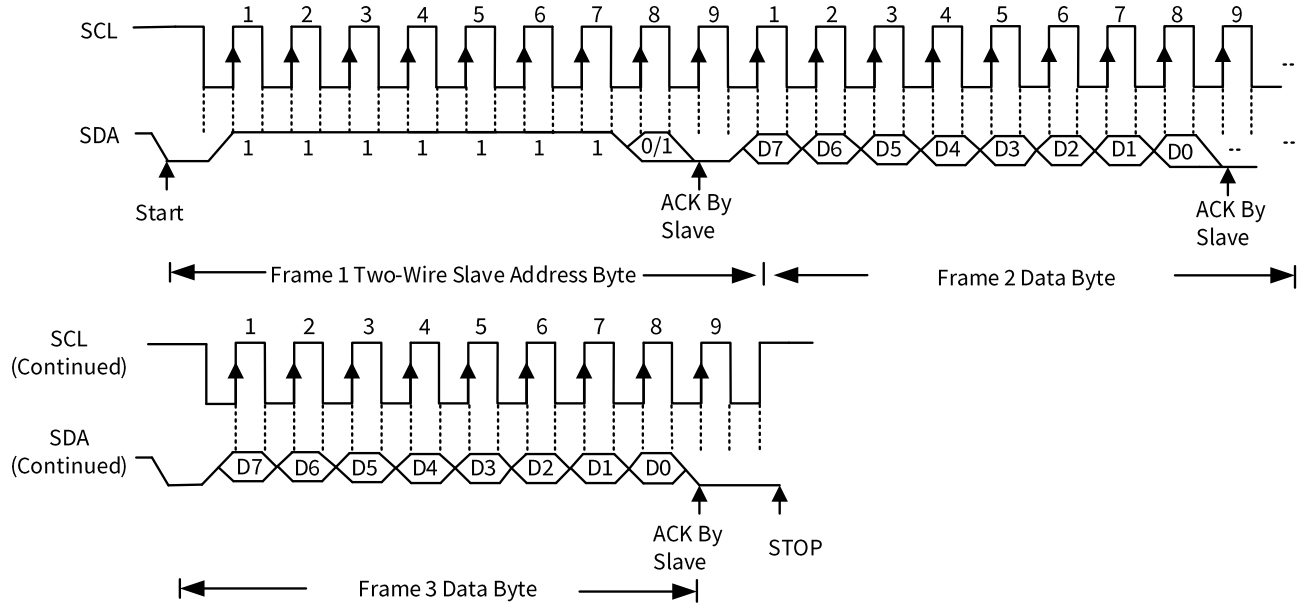

Figure 6.4 I<sup>2</sup>C Protocol

Byte Write

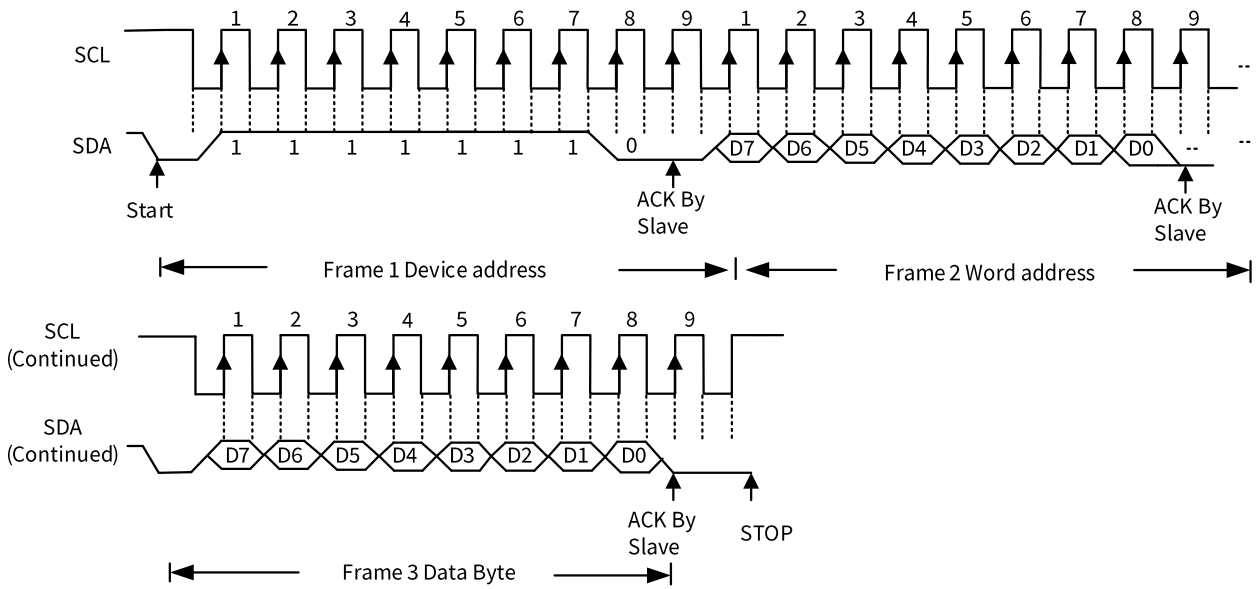

Figure 6.5 I<sup>2</sup>C Write Byte

Random Read

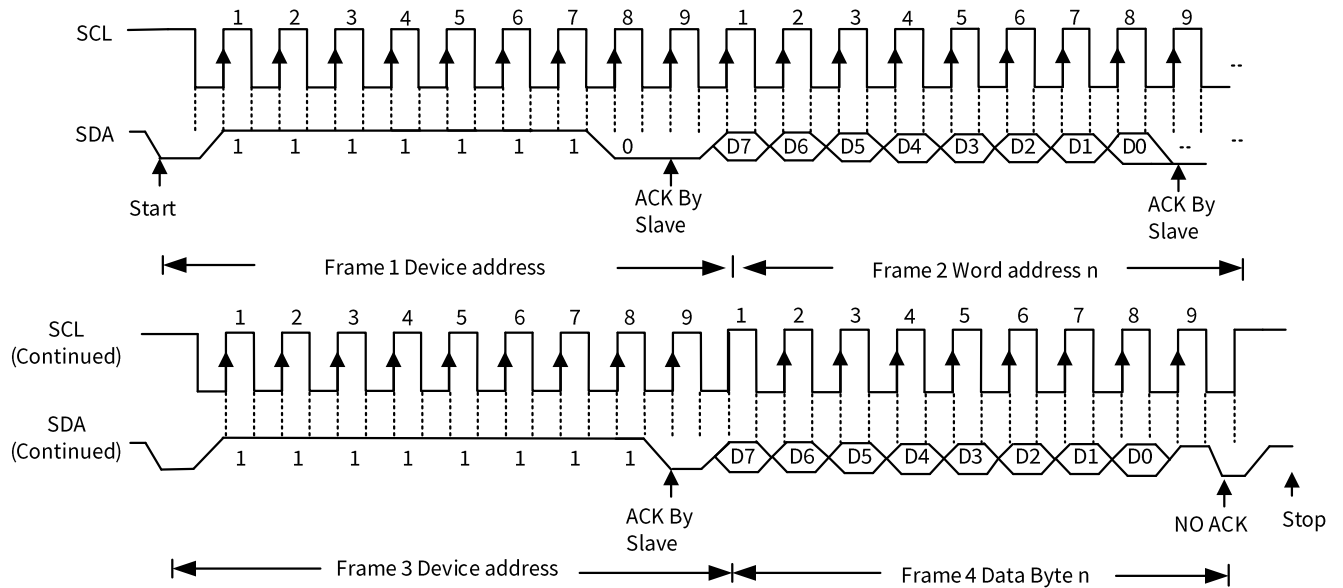

Figure 6.6 I<sup>2</sup>C Read Byte

## 7. Typical Application

### 7.1. Application Circuit

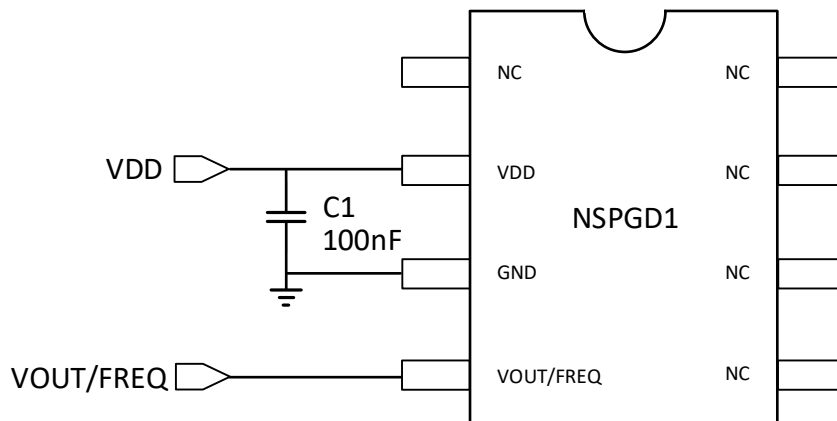

Figure 7.1 Analog/ Frequency Output Application Circuit

Note: For applications with higher ESD requirements, it is recommended that customers use the Figure 7.2 protection circuits.

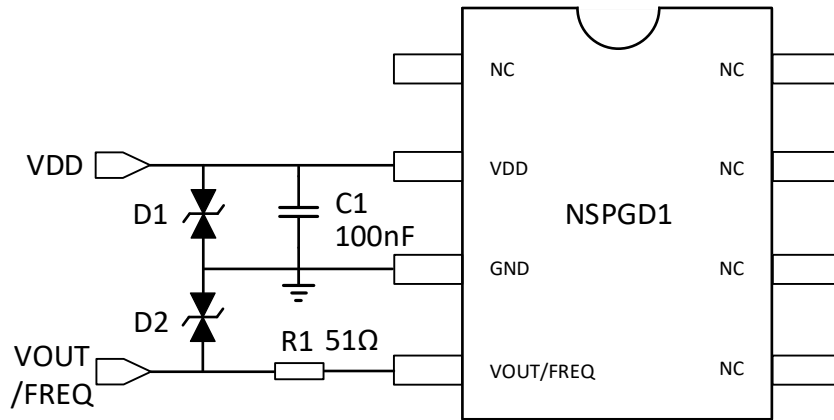

Figure 7.2 Analog/ Frequency Output Protection Circuit

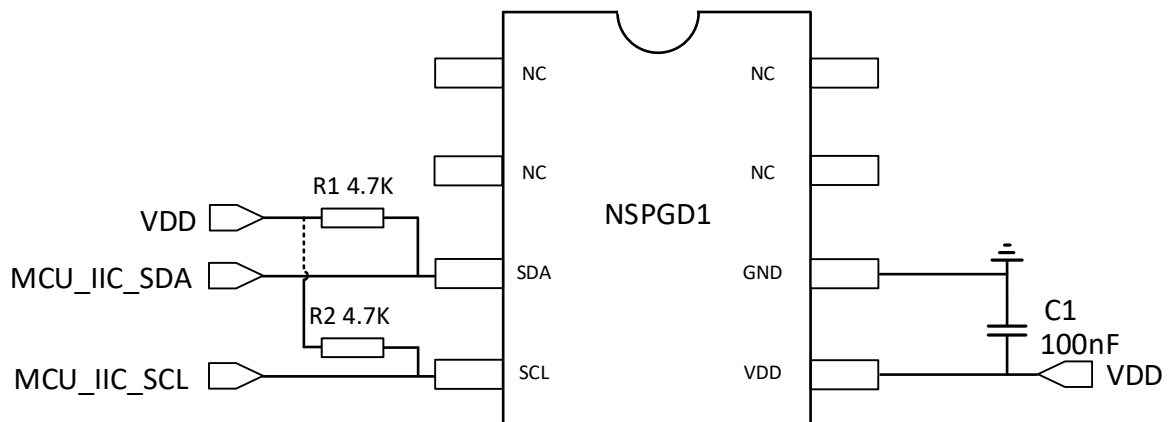

Figure 7.3 I²C Output Application Circuit

## 8. Package Information

### 8.1. Package Size

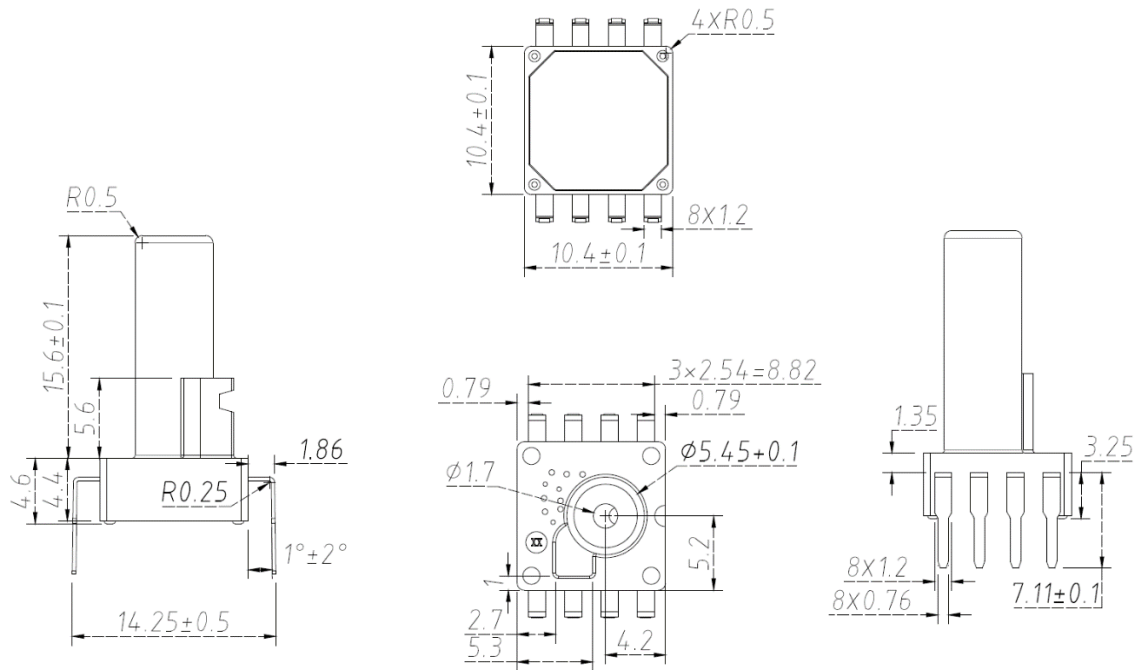

Figure 8.1 Package Outline mm

### 8.2. Recommended Footprint

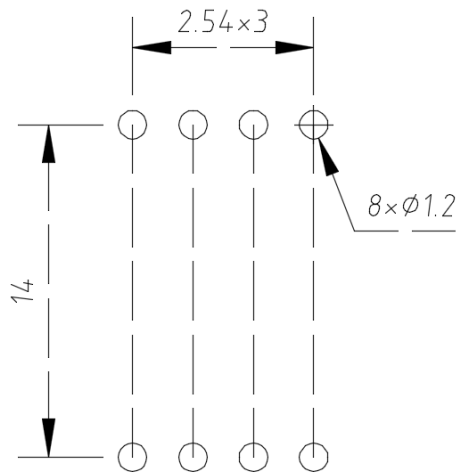

Figure 8.2 Footprint mm

### 9. Order Information

Product Type	Output Type	Pressure Range		Output Range		Clamp Level		Gain and Offset		Supply Voltage	Accuracy@0~70°C	
		P <sub>L</sub>	P <sub>H</sub>	O <sub>L</sub>	O <sub>H</sub>	V <sub>CL</sub>	V <sub>CH</sub>	A	B		Initially	Full Life
NSPGD1F002RT02	Ratiometric	0kPa	2kPa	0.50V	4.50V	4.76%	94%	0.40000	0.10000	5.0V	±1%	±2.5%
NSPGD1F004RT03	Ratiometric	0kPa	3.92kPa	1.00V	4.92V	0%	100%	0.20000	0.20000	5.0V	±1%	±2.5%
NSPGD1F006DT04	I <sup>2</sup> C	0kPa	6kPa	838861	7549746	NA	NA	0.13333	0.10000	5.0V	±1%	±2%
NSPGD1F003AT05	Absolute	0mmH2O	325mmH2O	0.50V	4.50V	0%	100%	0.00246	0.10000	5.0V	±1%	±2.5%
NSPGD1F005AT06	Absolute	0mmH2O	450mmH2O	0.50V	4.50V	0%	100%	0.00178	0.10000	5.0V	±1%	±2.5%
NSPGD1F010RT07	Ratiometric	0kPa	10kPa	0.50V	4.50V	0%	100%	0.08000	0.10000	5.0V	±1%	±2%
NSPGD1F010DT10	I <sup>2</sup> C	0kPa	10kPa	838861	7549746	NA	NA	0.08000	0.10000	3.3V	±1%	±2%
NSPGD1F004FT12	Frequency	0mmH2O	350mmH2O	3.125kHz	28.125kHz	NA	NA	0.002286	0.10000	5.0V	±1%	±2.5%
NSPGD1F005AT14	Absolute	0kPa	5kPa	0.50V	4.50V	0%	100%	0.16000	0.10000	5.0V	±1%	±2.5%
NSPGD1F010AT16	Absolute	0kPa	10kPa	0.33V	2.97V	0%	100%	0.08000	0.10000	3.3V	±1%	±2%

Please scan the following QR code for complete part number list.

<https://novosns.com/Public/Uploads/uploadfile4/nspgd1-series.pdf>



NSPGD1 Series

Naming Convention:

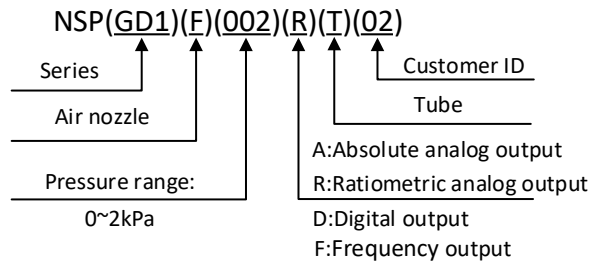

## 10. Identification Code

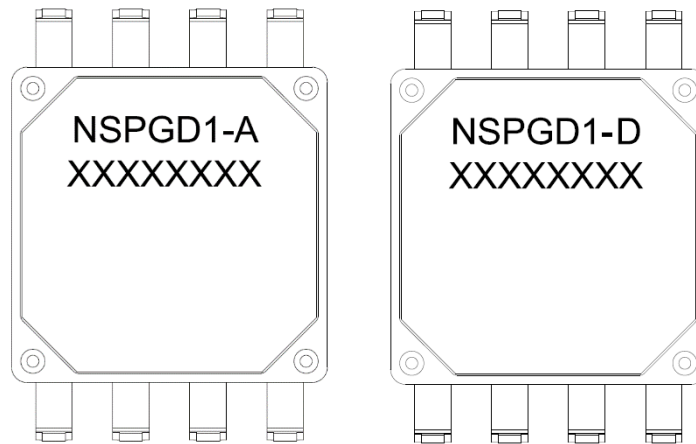

NSPGD1: Series name.

A: Analog output.

D: Digital output.

xxxxxxx: Package date code.

## 11. Soldering Parameters

### (1) Manual Soldering

- Please use an electric soldering iron with a tip temperature of 300~350°C to complete the soldering within 5 seconds.
- If a load is applied to the terminal during soldering, the sensor output may change.
- Please keep the solder tip clean and avoid using corrosive flux.

### (2) Wave Soldering

- Please keep the wave solder tank temperature below 255 °C and complete the soldering within 5 seconds.
- Since the MEMS pressure sensor is sensitive to temperature, it is recommended to verify the parameters of the wave soldering equipment in small batches, and then produce in large quantities after confirming the product performance.

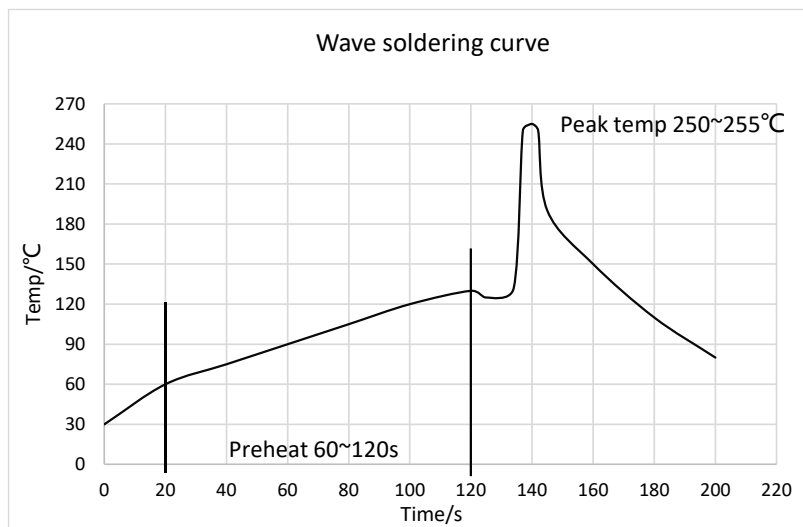

Figure 11.1 Wave Soldering Curve



Table 11.1 Wave Soldering Parameter

<i>Wave Soldering Condition</i>		<i>Lead-free Assembly</i>
Preheat	Temperature Min	110°C
	Temperature Max	130°C
	Time (min to max)	60~120s
Preheat Average Ramp Up Rate		1~3 °C/sec
Wave Soldering Peak Temperature		250~255°C
Time of Peak Temperature		<5sec
Chain Speed		1000~1300mm/min

## (3) Circuit Board Protective Paint

- When applying circuit board protective paint after soldering, avoid blocking the atmospheric reference port next to the sensor air nozzle, otherwise the sensor output will be abnormal.

## (4) Applicable Pressure Medium

- Not recommended for acidic and alkaline air and liquid measurements.

## 12. Packing Information

This Series product using tube package, each tube contains 50ea devices. Each tube has a blue plug as the bottom and a white plug as the top. The schematic diagram of tube is as follows:

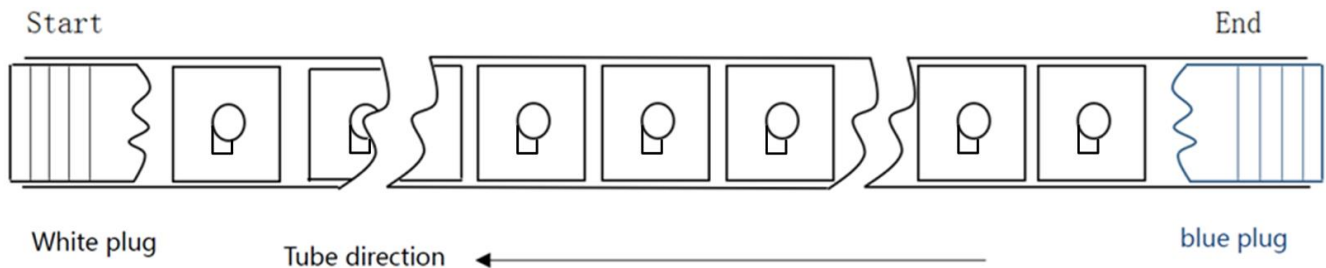

Minimum ordering quantity (MOQ): 1000EA.

Standard pack quantity (SPQ): 500EA.

### 13. Revision History

<i>Revision</i>	<i>Description</i>	<i>Date</i>
1.0	Initial Version.	2021/3/25
1.1	Add Frequency Output Type, Add Protection Circuit, Update Order Information.	2022/2/7
1.2	Add Soldering Parameters, Update Order Information, Update Package Information, Add Important Notice.	2022/6/1
1.3	Update Order Information, I <sup>2</sup> C Protocol Description.	2023/4/27
2.0	Formal Release.	2023/12/12

**Notes:**1. I<sup>2</sup>C code

```
#define ACK 1
#define NACK 0
uchar REG06=0,REG07=0,REG08=0;
uchar number=1;
uchar Reg30[1];
int PCode=0, Pdata=0;
float Pressure=0.0;
void IIC_Start(void) //Start the IIC, SDA High-to-low when SCL is high
{
    IIC_SCL(1); //SCL output high level
    SDA_OUT(1); //SDA output high level
    Delay_us(2); //Delay 2us
    SDA_OUT(0); //SDA output low level
    Delay_us(2);
}

void IIC_Stop(void) //Stop the IIC, SDA Low-to-high when SCL is high
{
    IIC_SCL(0);
    Delay_us(2);
    IIC_SCL(1);
    SDA_OUT(0);
    Delay_us(2);
    SDA_OUT(1);
    Delay_us(2);
}

void IIC_ACK(void) //Send ACK (LOW)
{
    SDA_OUT(0);
    IIC_SCL(1);
    Delay_us(2);
    IIC_SCL(0);
}

void IIC_NACK(void) //Send No ACK (High)
{
    SDA_OUT(1);
    IIC_SCL(1);
    Delay_us(2);
    IIC_SCL(0);
}

uchar IIC_Wait_ACK(void) //Check ACK, if return 0, then right, if return 1, then error
{
```

```
int ErrTime=0;
SDA_IN(); //SDA set as input
IIC_SCL(1);
Delay_us(2);
while(Read_SDA)
{
    ErrTime++;
    if(ErrTime>200)
    {
        IIC_Stop();
        return 1;
    }
}
IIC_SCL(0);
SDA_OUT(0);
Delay_us(2);
return 0;
}

void IIC_Send(uchar IIC_Data) //Send a byte to IIC
{
    uchar i;
    IIC_SCL(0);
    Delay_us(2);
    for(i=0;i<8;i++)
    {
        if((IIC_Data&0x80)>>7)
            SDA_OUT(1);
        else
            SDA_OUT(0);
        IIC_Data<<=1;
        IIC_SCL(1);
        Delay_us(2);
        IIC_SCL(0);
        Delay_us(2);
    }
}

uchar IIC_Receive(uchar ACK) //Receive a byte from IIC
{
    uchar i,Receive_Data=0;
    SDA_IN();
    for(i=0;i<8;i++)
    {
        IIC_SCL(0);
        Delay_us(2);
        IIC_SCL(1);
        Receive_Data<<=1;
        if(Read_SDA==1)
```

```
        Receive_Data++;
        Delay_us(2);
    }
    IIC_SCL(0);
    Delay_us(2);
    if(ACK==0x01)
        IIC_ACK();
    else
        IIC_NACK();
    return Receive_Data;
}

void NSPGD1F006DT04_Write_Byte(uchar WriteAddr,uchar WriteData)
{
    IIC_Start();
    IIC_Send(0xFE|0x00);
    IIC_Wait_ACK();
    IIC_Send(WriteAddr);
    IIC_Wait_ACK();
    IIC_Send(WriteData);
    IIC_Wait_ACK();
    IIC_Stop();
}

void NSPGD1F006DT04_Read_Byte(uchar ReadAddr, uchar *pBuffer)
{
    IIC_Start();
    IIC_Send(0xFE|0x00);
    IIC_Wait_ACK();
    IIC_Send(ReadAddr);
    IIC_Wait_ACK();
    IIC_Start();
    IIC_Send(0xFE|0x01);
    IIC_Wait_ACK();
    pBuffer[0]=IIC_Receive(0);
    IIC_Stop();
}

void NSPGD1F006DT04_Read_3Byte(uchar ReadAddr,uchar *pBuffer)
{
    IIC_Start();
    IIC_Send(0xFE|0x00);
    IIC_Wait_ACK();
    IIC_Send(ReadAddr);
    IIC_Wait_ACK();
    IIC_Start();
    IIC_Send(0xFE|0x01);
    IIC_Wait_ACK();
    pBuffer[0]=IIC_Receive(ACK);
```

```

    pBuffer[1]=IIC_Receive(ACK);
    pBuffer[2]=IIC_Receive(NACK);
    IIC_Stop();
}

void main()
{
    uchar PData[3]={0,0,0};
    while(1)
    {
        NSPGD1F006DT04_Write_Byte(0x30,0x0A);
        while(1)                                     //Check whether the conversion ends
        {
            if(number<=50)
            {
                number++;
                delay_ms(1);
                NSPGD1F006DT04_Read_Byte(0x30,Reg30);
                if(0x02==Reg30[0])
                {
                    number=1;
                    break;
                }
            }
            if(number>50)
            {
                number=1;
                //User can add his own error handler function
                break;
            }
        }
        NSPGD1F006DT04_Read_3Byte(0x06,PData);
        REG06 = PData [0];                             //Register 0x06
        REG07 = PData [1];                             //Register 0x07
        REG08 = PData [2];                             //Register 0x08
        PCode=(REG06*65536+REG07*256+REG08);           //PCode = Data0x06*2^16+ Data0x07*2^8+ Data0x08
        if (PCode >8388607)
            Pdata= PCode-16777216;                     //Symbol processing
        else
            Pdata= PCode;
        Pressure =((float)Pdata/8388607-0.1)/(0.13333); //PCode=(AxP+B)*8388607  P=(PCode/8388607-B)/A
                                                    //A=0.13333, B=0.1
                                                    //PNormalized=PCode/8388607
    }
}

```

## **IMPORTANT NOTICE**

The information given in this document (the “Document”) shall in no event be regarded as any warranty or authorization of, express or implied, including but not limited to accuracy, completeness, merchantability, fitness for a particular purpose or infringement of any third party’s intellectual property rights.

Users of this Document shall be solely responsible for the use of NOVOSENSE’s products and applications, and for the safety thereof. Users shall comply with all laws, regulations and requirements related to NOVOSENSE’s products and applications, although information or support related to any application may still be provided by NOVOSENSE.

This Document is provided on an “AS IS” basis, and is intended only for skilled developers designing with NOVOSENSE’ products. NOVOSENSE reserves the rights to make corrections, modifications, enhancements, improvements or other changes to the products and services provided without notice. NOVOSENSE authorizes users to use this Document exclusively for the development of relevant applications or systems designed to integrate NOVOSENSE’s products. No license to any intellectual property rights of NOVOSENSE is granted by implication or otherwise. Using this Document for any other purpose, or any unauthorized reproduction or display of this Document is strictly prohibited. In no event shall NOVOSENSE be liable for any claims, damages, costs, losses or liabilities arising out of or in connection with this Document or the use of this Document.

For further information on applications, products and technologies, please contact NOVOSENSE ([www.novosns.com](http://www.novosns.com)).

**Suzhou NOVOSENSE Microelectronics Co., Ltd**