

Product Overview

NCA3176 is a half-duplex RS-485 transceiver and NCA3492 is a full-duplex RS-485 transceiver, both with a power supply range of 3.0 to 5.5V. They exceed TIA-485-A specification and industrial applications.

The devices have a 1/8-unit-load receiver input impedance that allows up to 256 transceivers on the bus. The data rate of the device is up to 20Mbps. The devices are slew limited to reduce EMI and reflections with improperly terminated transmission line.

The Bus pins are protected from $\pm 8\text{kV}$ system level ESD to GND. The devices feature fail-safe circuitry, which guarantee a logic-high receiver output when the receiver inputs are open or shorted.

Key Features

- Power supply voltage: 3.0V to 5.5V
- Individual driver and receiver enable
- High system level EMC performance:
Bus Pins meet IEC61000-4-2 $\pm 8\text{kV}$ ESD
- Fail-safe protection receiver
- Up to 256 transceivers on the bus
- Operation temperature: $-40^{\circ}\text{C} \sim 125^{\circ}\text{C}$
- RoHS-compliant packages:
SOP8
MSOP8
SOP14
- Exceeds TIA-485-A Specifications
- Signaling Rate up to 20 Mbps

Applications

- Industrial automation system
- RS-485 communication
- E-Metering Networks
- Motion Controllers

Device Information

Part Number	Package	Body Size
NCA3176-DSPR	SOP8	4.90mm × 3.90mm
NCA3176-DMSR	MSOP8	3.00mm × 3.00mm
NCA3492-DSPKR	SOP14	8.65mm × 3.90mm

Functional Block Diagrams

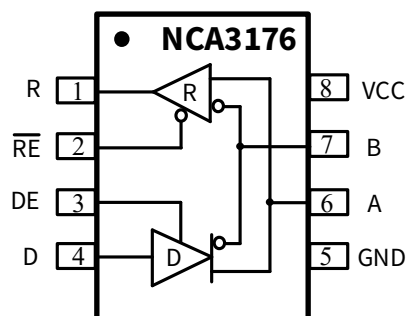

Figure 1. NCA3176 Block Diagram

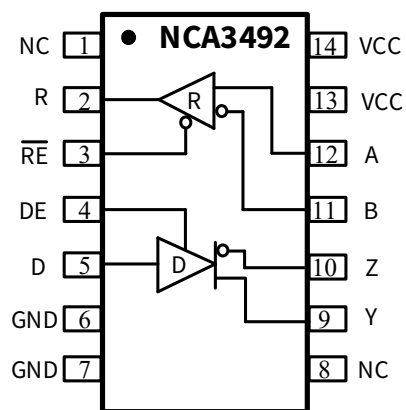

Figure 2. NCA3492 Block Diagram

INDEX

1. PIN CONFIGURATION AND FUNCTIONS	3
2. ABSOLUTE MAXIMUM RATINGS	4
3. ESD RATINGS	5
4. RECOMMENDED OPERATING CONDITIONS	5
5. THERMAL INFORMATION	5
6. SPECIFICATIONS	6
6.1. ELECTRICAL CHARACTERISTICS	6
6.2. SWITCHING ELECTRICAL CHARACTERISTICS	7
6.3. PARAMETER MEASUREMENT INFORMATION	8
6.4. TYPICAL PERFORMANCE CHARACTERISTICS	11
7. FUNCTION DESCRIPTION	11
7.1. OVERVIEW	11
7.2. DATA RATE	11
7.3. FUNCTIONAL BLOCK DIAGRAM	11
7.4. TRUE FAIL-SAFE RECEIVER INPUTS	12
7.5. TRUTH TABLES	12
7.6. THERMAL SHUTDOWN	13
8. APPLICATION NOTE	14
8.1. TYPICAL APPLICATION CIRCUIT	14
8.2. PCB LAYOUT	14
8.3. NODES ON THE BUS	14
8.4. ESD PROTECTION	15
8.5. SURGE PROTECTION	15
9. PACKAGE INFORMATION	16
10. ORDERING INFORMATION	17
11. TAPE AND REEL INFORMATION	18
12. REVISION HISTORY	21

1. Pin Configuration and Functions

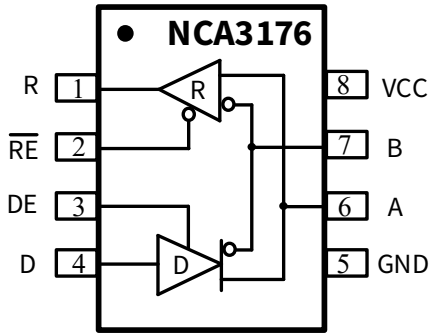

Figure 1.1 NCA3176 Package

Table 1.1 NCA3176 Pin Configuration and Description

NCA3176 PIN NO.	SYMBOL	FUNCTION
1	R	Receive output
2	/RE	Receive enable input. This is an active low input.
3	DE	Driver enable input. This is an active high input
4	D	Driver transmit data input.
5	GND	Ground.
6	A	Noninverting Driver Output/Receiver Input. When the driver is disabled, or when VDD is powered down, Pin A is put into a high impedance state to avoid overloading the bus.
7	B	Inverting Driver Output/Receiver Input. When the driver is disabled, or when VDD is powered down, Pin B is put into a high impedance state to avoid overloading the bus.
8	VCC	Power Supply.

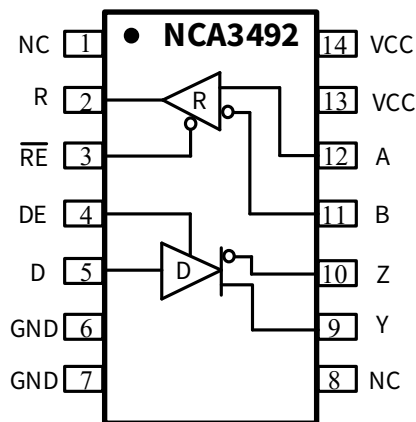

Figure 1.2 NCA3492 Package

Table 1.2 NCA3492 Pin Configuration and Description

NCA3492 PIN NO.	SYMBOL	FUNCTION
1	NC	No Connection.
2	R	Receive output
3	/RE	Receive enable input. This is an active low input.
4	DE	Driver enable input. This is an active high input
5	D	Driver transmit data input.
6	GND	Ground.
7	GND	Ground.
8	NC	No Connection.
9	Y	Noninverting Driver Output. When the driver is disabled, or when VCC is powered down, Pin Y is put into a high impedance state to avoid overloading the bus.
10	Z	Inverting Driver Output. When the driver is disabled, or when VCC is powered down, Pin Z is put into a high impedance state to avoid overloading the bus.
11	B	Inverting Receiver Input.
12	A	Noninverting Receiver Input.
13	VCC	Power Supply.
14	VCC	Power Supply.

2. Absolute Maximum Ratings

Parameters	Symbol	Min	Typ	Max	Unit	Comments
Power Supply Voltage	VCC	-0.5		6	V	
Maximum Input Voltage	/RE, DE, D	-0.4		VCC+0.4	V	
Driver Output/Receiver Input Voltage	V _A , V _B , V _V , V _Z	-18		18	V	
Differential input voltage, A with respect to B	V _{ID}	-18		18	V	
Receiver Output Current	I _o	-15		15	mA	
Operating Temperature	T _{opr}	-40		125	°C	
Storage Temperature	T _{stg}	-40		150	°C	
Junction Temperature	T _j	-40		150	°C	

3. ESD Ratings

Ratings		Value	Unit
Electrostatic discharge	Human body model (HBM), per AEC-Q100-002-RevD ● All pins	±8.0	kV
	Charged device model (CDM), per AEC-Q100-011-RevB ● All pins	±2.0	kV
	IEC61000-4-2 (Bus pins)	±8.0	kV

4. Recommended Operating Conditions

Parameters	Symbol	Min	Typ	Max	Unit	Comments
Power Supply Voltage	VCC	3		5.5	V	
High-level Input Voltage	V _{IH}	2		VCC	V	
Low-level Input Voltage	V _{IL}	0		0.8	V	
Voltage at any bus terminal (separately or common mode)	V _I	-7		12	V	
Differential input voltage	V _{ID}	-12		12	V	
High-level output current	I _{OH}	-8			mA	
Low-level output current	I _{OL}			8	mA	
Ambient Temperature	T _a	-40		125	°C	

5. Thermal Information

Parameters	Symbol	SOP8	MSOP8	SOP14	Unit
Junction-to-ambient thermal resistance	θ _{JA}	67.9	168.7	96.25	°C/W
Junction-to-case(top) thermal resistance	θ _{JC (top)}	27.7	62.2	50	°C/W
Junction-to-board thermal resistance	θ _{JB}	29.4	89.5	61	°C/W

6. Specifications

6.1. Electrical Characteristics

(VCC=3.0V~5.5V, Ta=-40°C to 125°C. Unless otherwise noted, Typical values are at VCC = 5.0V, Ta = 25°C)

Parameters	Symbol	Min	Typ	Max	Unit	Comments
Power supply voltage	VCC	3.0		5.5	V	
supply current	I _{CC}		900	1800	μA	DE=High, /RE=Low, no load
			600	1000	μA	DE=High, /RE=High, no load
			630	1200	μA	DE=Low, /RE=Low, no load
			0.5	5	μA	DE=Low, /RE=High, no load
Thermal-Shutdown Threshold	T _{TS}		165		°C	
Thermal-Shutdown Hysteresis	T _{TSH}		15		°C	
Logic Side						
Input High Voltage	V _{IH}	2			V	DE, D, /RE
Input Low Voltage	V _{IL}			0.8	V	DE, D, /RE
Input Current	I _{IN}	-2		2	μA	DE, D, /RE
Output Voltage High	V _{OH}	VCC-0.5			V	I _{OH} = -8mA, R
Output Voltage Low	V _{OL}			0.5	V	I _{OL} = 8mA, R
Output Short-Circuit Current	I _{OSR}	-95		95	mA	0 ≤ V _R ≤ VCC
Three-State Output Current	I _{OZR}	-15		1	μA	0 ≤ V _R ≤ VCC, /RE = High
Driver						
Input clamp voltage	V _{IK}	-1.5			V	I _I = -18 mA
Differential Output Voltage	V _{OD}			VCC	V	No Load
		1.5	2		V	see Figure 6. 1, R _L =54Ω(RS-485)
		2	2.5		V	see Figure 6. 2, R _L =100Ω (RS-422), VCC ≥ 3.2V, T _j ≥ 0°C
		1.5	2		V	see Figure 6. 3, R _L =60Ω , 375Ω on each output to -7V to 12V
Change in magnitude of the differential output voltage	Δ V _{OD}	-200		200	mV	See Figure 6. 1, R _L =54Ω, C _L =50pF
Steady-state common-mode output voltage	V _{OC}	1	VCC/2	3.5	V	See Figure 6. 4
Change in differential driver output common-mode voltage	ΔV _{OC(SS)}	-200		200	mV	See Figure 6. 4

Peak-to-peak driver common-mode output voltage	$V_{OC(PP)}$		450		mV	See Figure 6. 4
Driver Short-Circuit Output Current	I_{OSD}	-250		250	mA	$-7V \leq V_o \leq +12V$
Output Leakage Current (Y and Z) Full-Duplex	I_i			200	μA	$V_i = 12V, DE=Low$
		-200				$V_i = -7V, DE=Low$
Receiver						
Positive-going receiver differential input voltage threshold	V_{TH+}			-10	mV	DE=/RE=Low
Negative-going receiver differential input voltage threshold	V_{TH-}	-200			mV	DE=/RE=Low
Receiver differential input voltage threshold hysteresis	V_{hys-}		30		mV	DE=/RE=Low
Bus input current (disabled driver)	I_i			200	μA	$V_i = 12V, DE=Low$
		-200			μA	$V_i = -7V, DE=Low$
Receiver Input Resistance	R_{IN}	96			k Ω	$-7V \leq V_i \leq 12V, DE=Low$

6.2. Switching Electrical Characteristics

(VDD=3.0V~5.5V, Ta=-40°C to 125°C. Unless otherwise noted, Typical values are at VCC = 5V Ta = 25°C)

Parameters	Symbol	Min	Typ	Max	Unit	Comments
Driver						
Maximum Data Rate	f_{MAX}			20	Mbps	
Driver Propagation Delay	t_{PLH}		6	15	ns	see Figure 6. 5, $R_L=54\Omega$, $C_L=50pF$
	t_{PHL}		6	15	ns	see Figure 6. 5, $R_L=54\Omega$, $C_L=50pF$
Driver pulse skew, $ t_{PHL} - t_{PLH} $			1	4	ns	
Driver Output Falling Time or Rising time	t_f		4.5	10	ns	see Figure 6. 5, $R_L=54\Omega$, $C_L=50pF$
	t_r		4.5	10	ns	see Figure 6. 5, $R_L=54\Omega$, $C_L=50pF$
Driver-Output enable time to high level	t_{PZH}			40	ns	See Figure 6. 6, /RE=Low
		1.5	6	μs	see Figure 6. 6, /RE=High	
Driver-Output enable time to low level	t_{PZL}			40	ns	see Figure 6. 7, /RE=Low
		1.5	6	μs	see Figure 6. 7, /RE=High	

Driver-Output disable time from high level	t_{PHZ}			50	ns	See Figure 6. 6
Driver-Output disable time from low level	t_{PLZ}			50	ns	see Figure 6. 7
Receiver						
Receiver Propagation Delay	t_{PLH}		70	130	ns	See Figure 6. 8, $C_L=15pF$
	t_{PHL}		70	130	ns	See Figure 6. 8, $C_L=15pF$
Receiver pulse skew, $ t_{PHL} - t_{PLH} $				5	ns	
Receiver Output Falling Time or Rising time	t_f		2	5	ns	see Figure 6. 8, $C_L=15pF$
	t_r		2	5	ns	see Figure 6. 8, $C_L=15pF$
Receiver Disable to Output High	t_{PHZ}			50	ns	see Figure 6. 9
Receiver Disable to Output Low	t_{PLZ}			50	ns	see Figure 6. 9
Receiver Enable to Output High	$t_{PZH(1)}$			145	ns	see Figure 6. 9,DE=High
	$t_{PZH(2)}$		1	6	μs	see Figure 6. 10,DE=Low
Receiver Enable to Output Low	$t_{PZL(1)}$			115	ns	see Figure 6. 9,DE=High
	$t_{PZL(2)}$		1	6	μs	see Figure 6. 10,DE=Low

6.3. Parameter Measurement Information

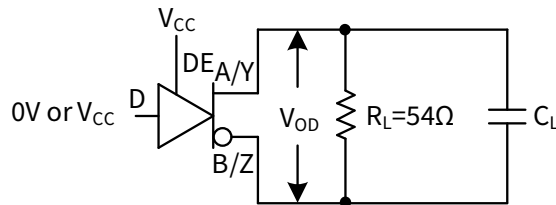

Figure 6. 1 Measurement of Driver Differential Output Voltage With RS-485 Load

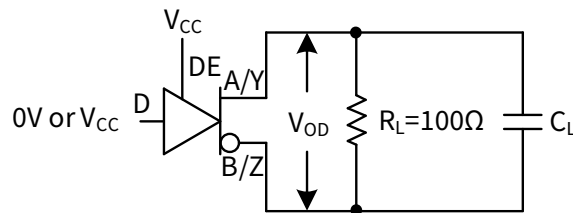

Figure 6. 2 Measurement of Driver Differential Output Voltage With RS-422 Load

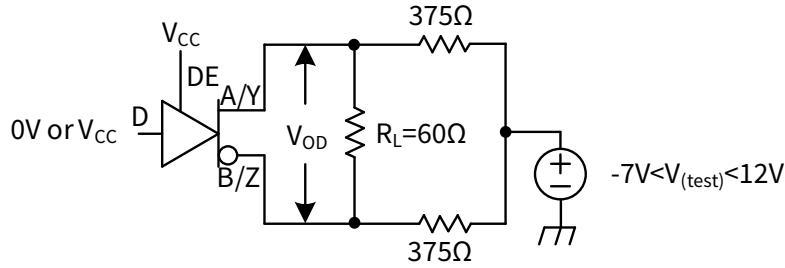

Figure 6. 3 Measurement of Driver Differential Output Voltage With Common-Mode Load

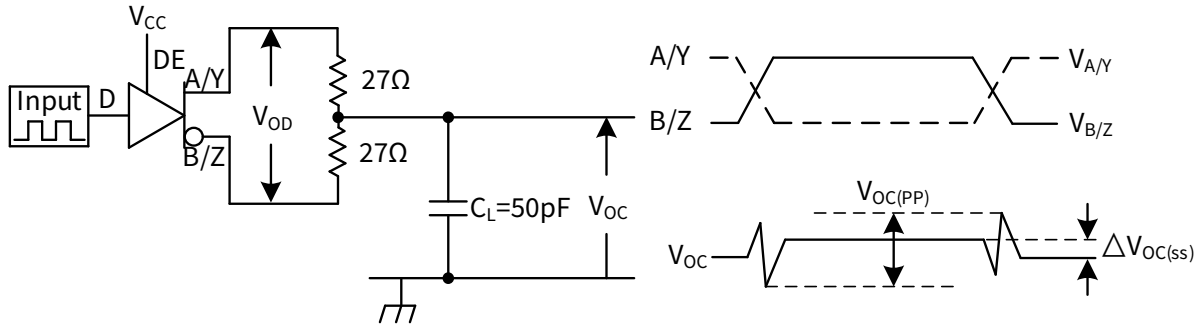

Figure 6. 4 Measurement of Driver Common-Mode Output Voltage With RS-485 Load

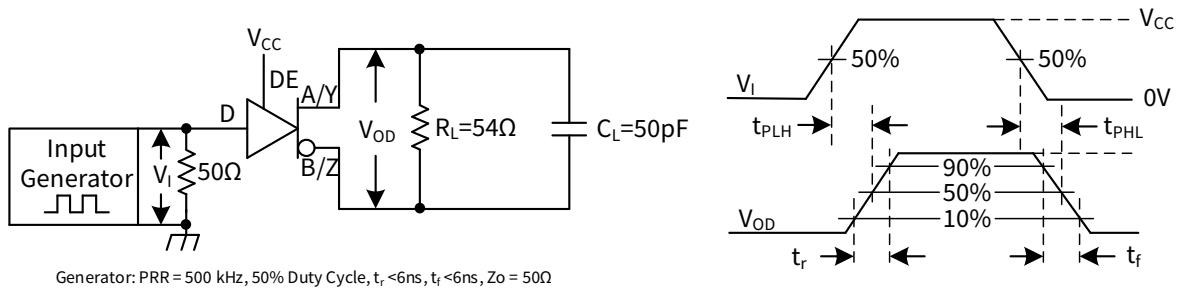

Figure 6. 5 Measurement of Driver Differential Output Rise and Fall Times and Propagation Delays of NCA3176 and NCA3492

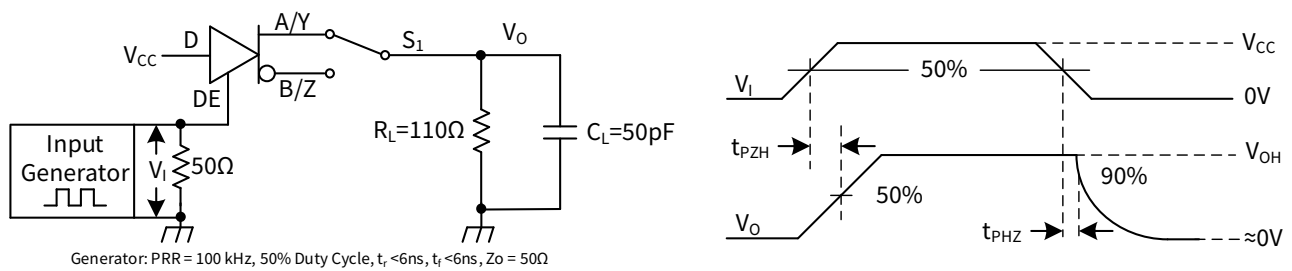

Figure 6. 6 Measurement of Driver Enable and Disable Times With Active High Output and Pull-Down Load of NCA3176 and NCA3492

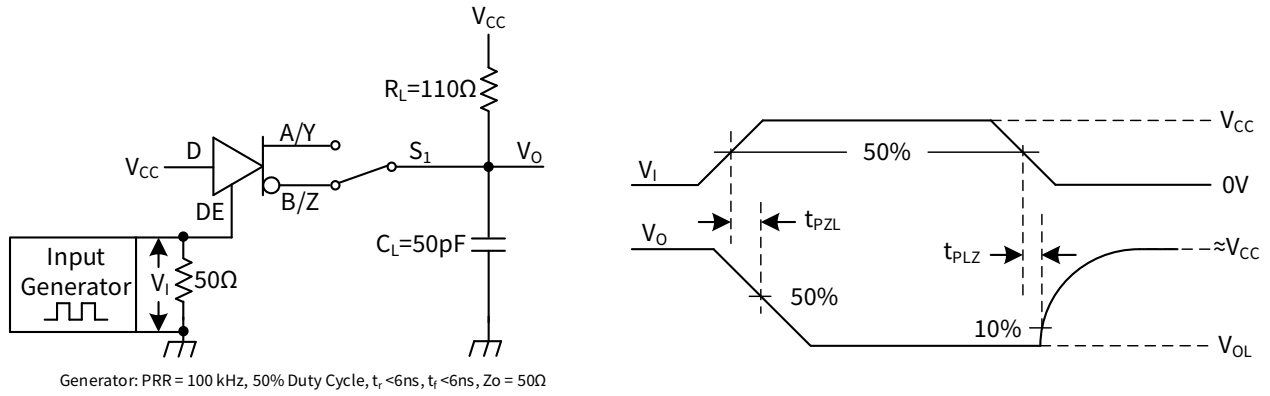

Figure 6. 7 Measurement of Driver Enable and Disable Times With Active Low Output and Pull-Up Load of NCA3176 and NCA3492

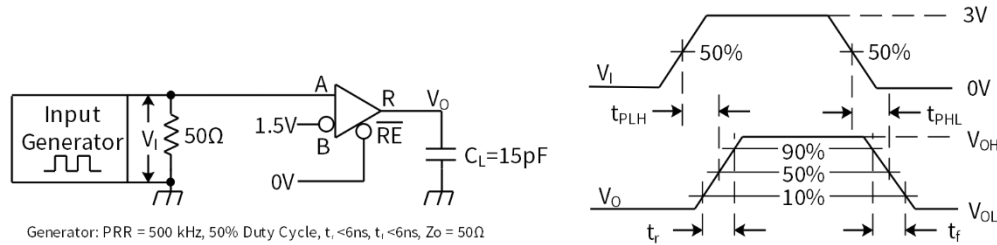

Figure 6. 8 Measurement of Receiver Output Rise and Fall Times and Propagation Delays of NCA3176 and NCA3492

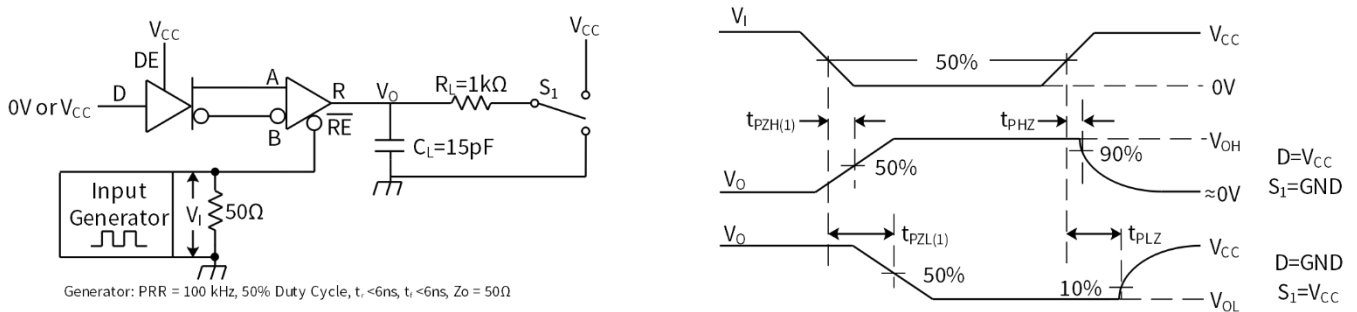

Figure 6. 9 Measurement of Receiver Enable/Disable Times With Driver Enabled of NCA3176 and NCA3492

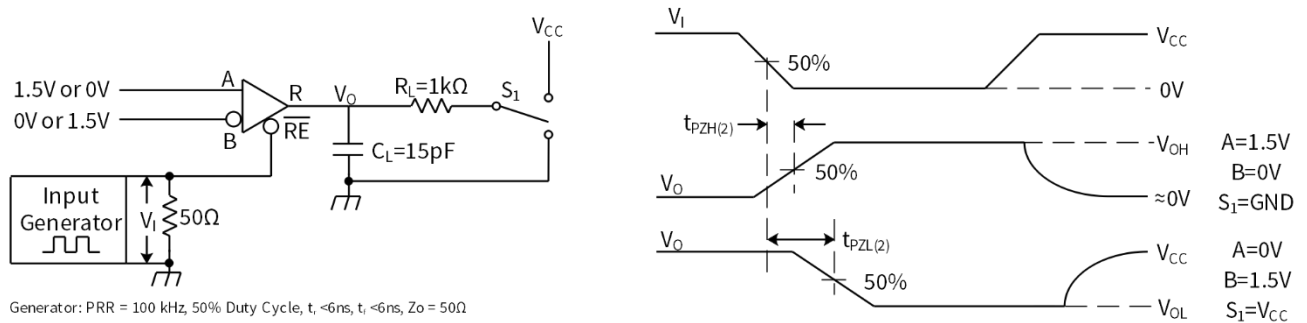

Figure 6. 10 Receiver Enable Time From Standby (Driver Disabled) of NCA3176 and NCA3492

6.4. Typical Performance Characteristics

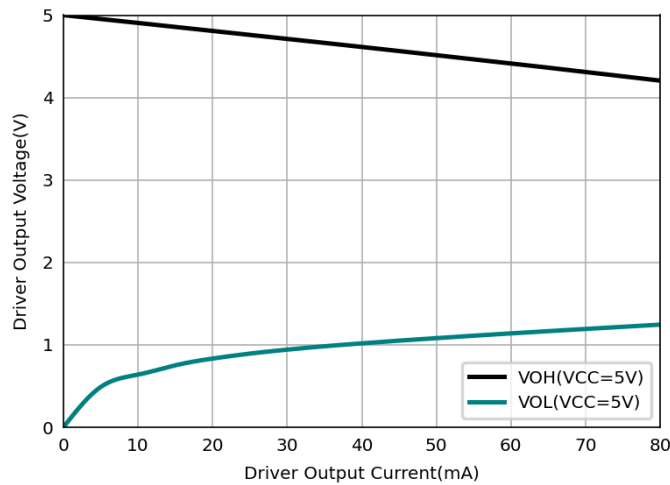

Figure 6.11 Relationship between driver voltage and current

7. Function Description

7.1. Overview

NCA3176 is a half-duplex RS-485 transceiver and NCA3492 is a full-duplex RS-485 transceiver, both with a power supply range of 3.0 to 5.5V. They exceed TIA-485-A specification and industrial applications. The devices have a 1/8-unit-load receiver input impedance that allows up to 256 transceivers on the bus. The data rate of the device is up to 20Mbps. The devices are slew limited to reduce EMI and reflections with improperly terminated transmission line. The Bus pins are protected from ±8kV system level ESD to GND. The devices feature fail-safe circuitry, which guarantee a logic-high receiver output when the receiver inputs are open or shorted.

7.2. Data rate

The data rate of NCA3176 and NCA3492 are 20Mbps. The devices are slew limited to reduce EMI and reflections with improperly terminated transmission line.

7.3. Functional Block Diagram

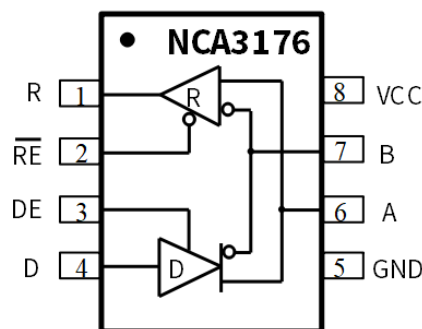

Figure 7. 1 NCA3176 Block Diagram

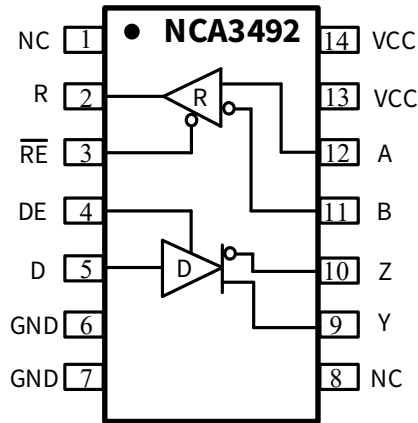

Figure 7.2 NCA3492 Block Diagram

7.4. True Fail-safe receiver inputs

The devices feature fail-safe circuitry, which guarantee a logic-high receiver output when the receiver inputs are open or shorted. The receiver threshold is fixed between -10mV and -200mV, which meets EIA/TIA-485 standard. If the differential input voltage ($V_A - V_B$) is greater than or equal to -10mV, receiver output R is logic high. In the case of a terminated bus with all transmitters disabled, the differential input voltage is pulled to zero by the termination resistors. Due to the receiver threshold, the receiver output R is logic high.

7.5. Truth tables

Table 7.1 Driver Function Table¹

Input (D)	Enable Input (DE)	Outputs ¹	
		A	B
H	H	H	L
L	H	L	H
X	L	Z	Z
X	OPEN	Z	Z
OPEN	H	L	H

H= Logic High; L= Logic Low; X= Irrelevant; Z= High Impedance.

Table 7.2 Receiver Function Table¹

Differential Input ($V_A - V_B$)	Enable Input (/RE)	Output (R)
$\geq -10\text{mV}$	L/Open	H
$\leq -200\text{mV}$	L/Open	L
Open/Short	L/Open	H
X	H	Z
Idle	L	H

H= Logic High; L= Logic Low; X= Irrelevant; Z= High Impedance.

7.6. Thermal shutdown

The devices are protected from over temperature damage by integrated thermal shutdown circuitry. When the junction temperature (T_j) exceeds +165°C (typ), the driver outputs go high-impedance. The devices resume normal operation when T_j falls below +145°C (typ).

8. Application Note

8.1. Typical Application Circuit

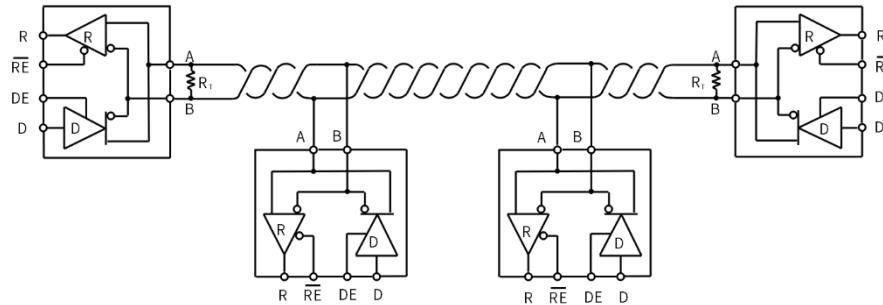

Figure 8.1 Typical RS-485 Network with Half-Duplex Transceivers

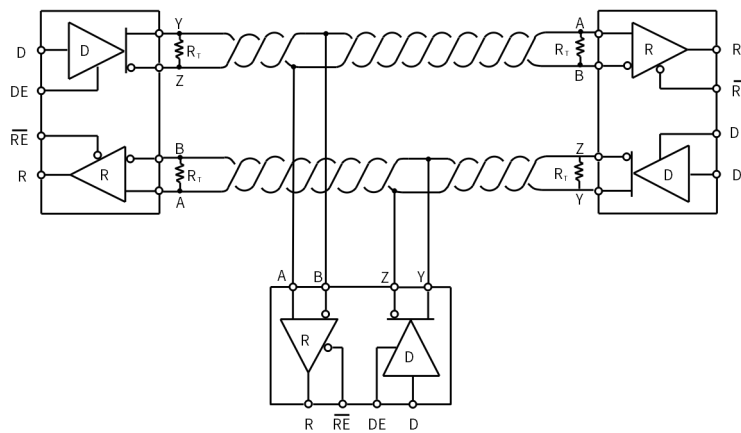

Figure 8.2 Typical RS-485 Network With Full-Duplex Transceivers

8.2. PCB Layout

The devices require a 0.1 μF bypass capacitor between VCC and GND. The capacitor should be placed as close as possible to the package. To eliminate line reflections, each cable end is terminated with a resistor, whose value matches the characteristic impedance of the cable. It's good practice to have the bus connectors and termination resistor as close as possible to the A and B Bus pins.

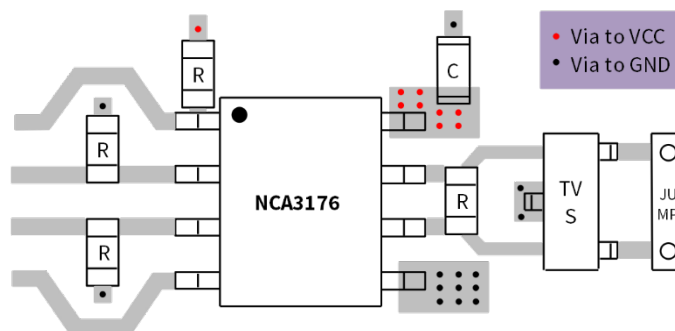

Figure 8.3 NCA3176 Layout Example

8.3. Nodes on the bus

The devices have a 1/8-unit-load receiver input impedance (96k Ω) that allows up to 256 transceivers on the bus. Connect any combination of these devices, and/or other RS-485 devices, for a maximum of 32 unit-loads to the line.

8.4. ESD protection

ESD protection structures are enhanced on all pins to protect against electrostatic discharge encountered during handling and assembly.

ESD protection can be tested in various ways. Below is the ESD spec of the devices.

Bus pins:

- $\pm 8\text{kV}$ HBM.
- $\pm 8\text{kV}$ using the contact discharge method specified in IEC 61000-4-2

Other pins except bus pins:

- $\pm 8\text{kV}$ HBM

8.5. Surge protection

If the surge is transient, the high energy content has the characteristics of long pulse duration and slow pulse power attenuation. The transient electrical energy injected into the protective unit inside the transceiver is converted to thermal energy, which heats up and destroys the protective unit, thus destroying the transceiver. Therefore, the following diagram shows a protection circuit against surge transients (IEC 61000-4-5). R_1 and R_2 are current limiting resistors.

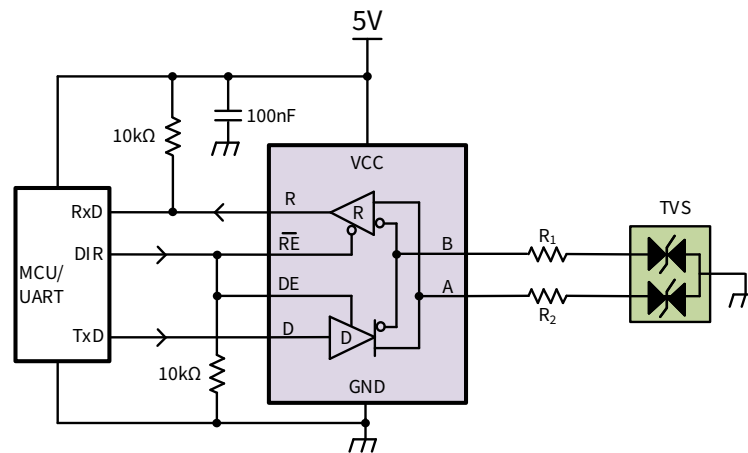
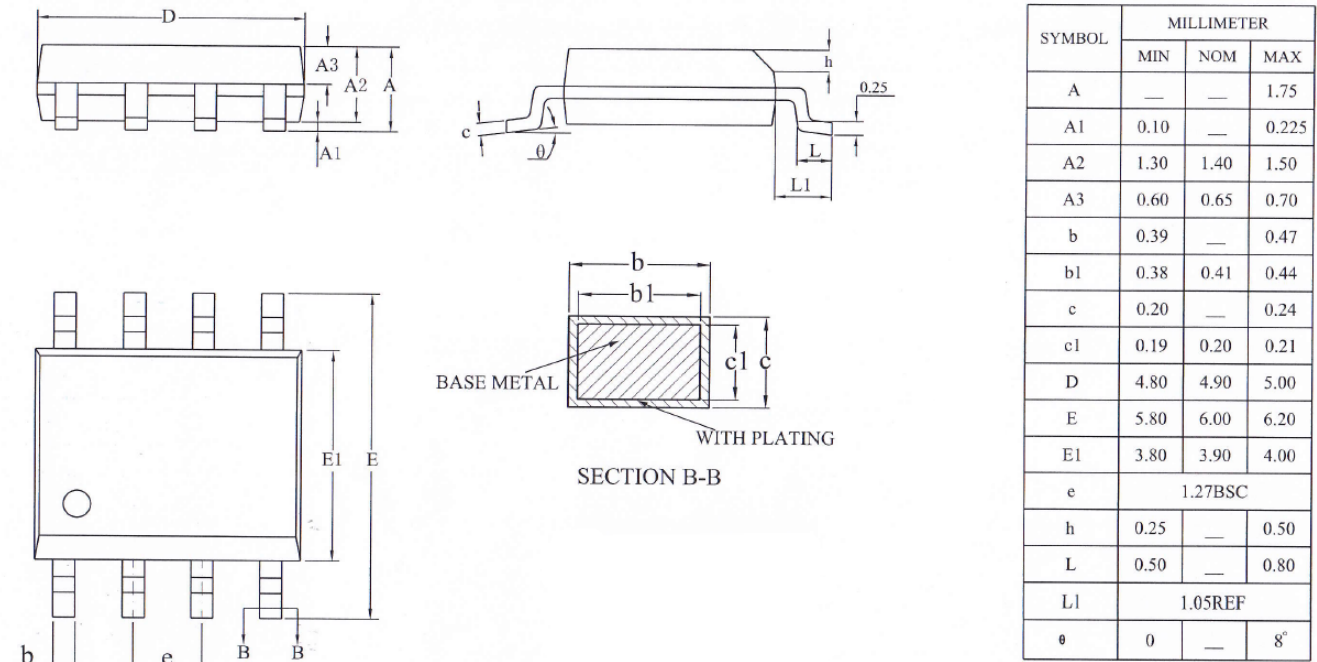

Figure 8.4 Transient protection against surge transients for half-duplex RS-485 transceiver

9. Package Information



NOTE: This dimension does not include mold flash, protrusions, or gate burrs. Mold flash, protrusions, or gate burrs shall not exceed 0.15 mm, per side.

Figure 9.1 SOP8 Package Shape and Dimension in millimeters

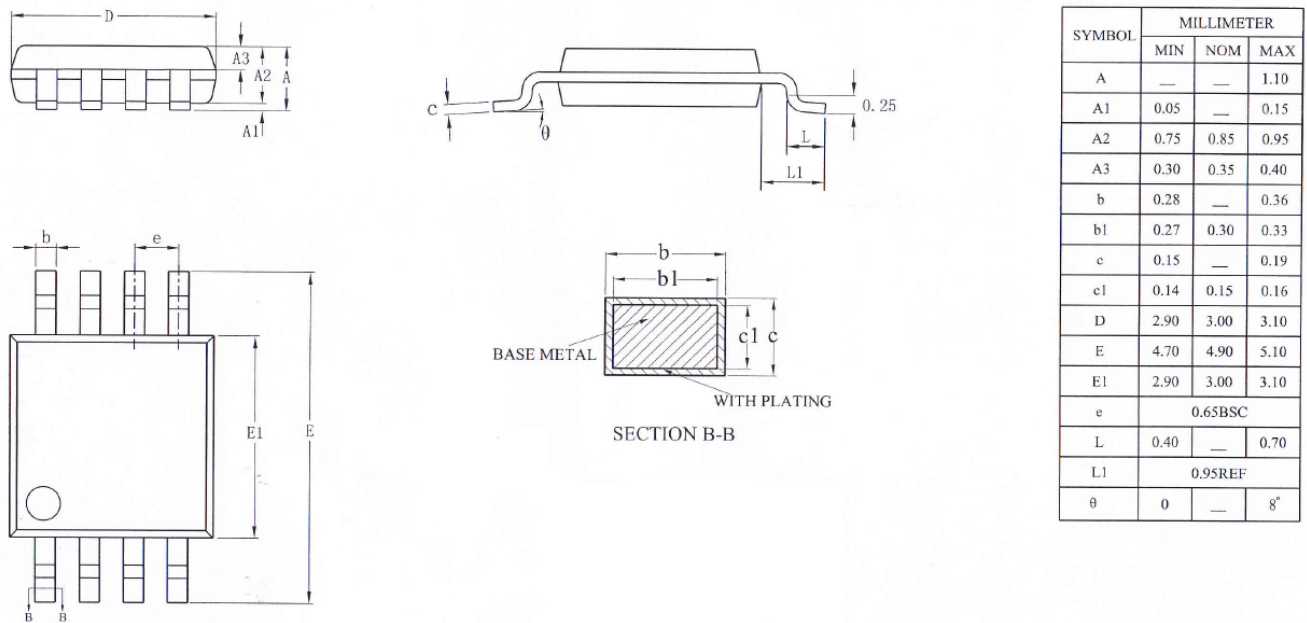

NOTE: This dimension does not include mold flash, protrusions, or gate burrs. Mold flash, protrusions, or gate burrs shall not exceed 0.15 mm, per side.

Figure 9.2 MSOP8 Package Shape and Dimension in millimeters

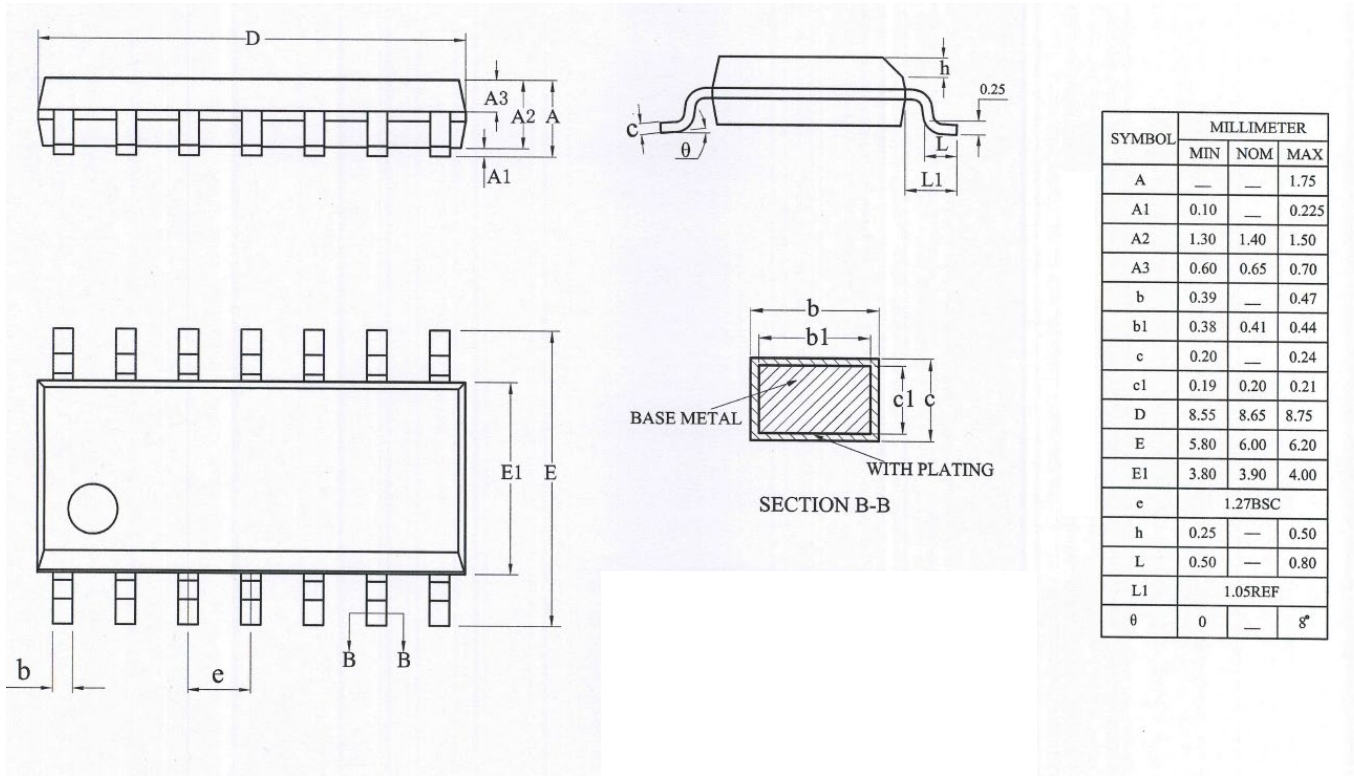

1

NOTE: This dimension does not include mold flash, protrusions, or gate burrs. Mold flash, protrusions, or gate burrs shall not exceed 0.15 mm, per side.

Figure 9.3 SOP14 Package Shape and Dimension in millimeters

10. Ordering Information

Part Number	Duplex	Max Data Rate (Mbps)	No. of Nodes	Temperature	MSL	Package Type	Package Drawing	SPQ
NCA3176-DSPR	Half	20	256	-40 to 125°C	3	SOP8	SOP8	4000
NCA3176-DMSR	Half	20	256	-40 to 125°C	3	MSOP8	MSOP8	4000
NCA3492-DSPKR	Full	20	256	-40 to 125°C	3	SOP14	SOP14	4000

NOTE: All packages are RoHS-compliant with peak reflow temperatures of 260 °C according to the JEDEC industry standard classifications and peak solder temperatures.

11. Tape and Reel Information

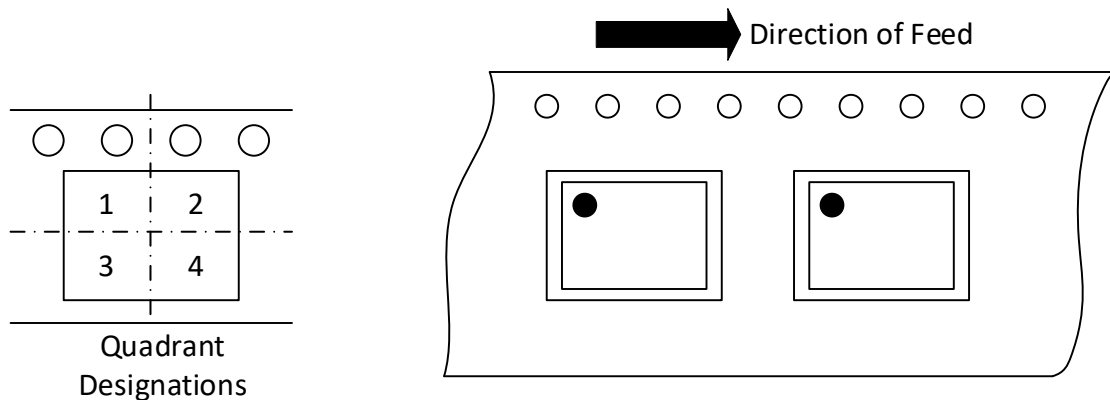
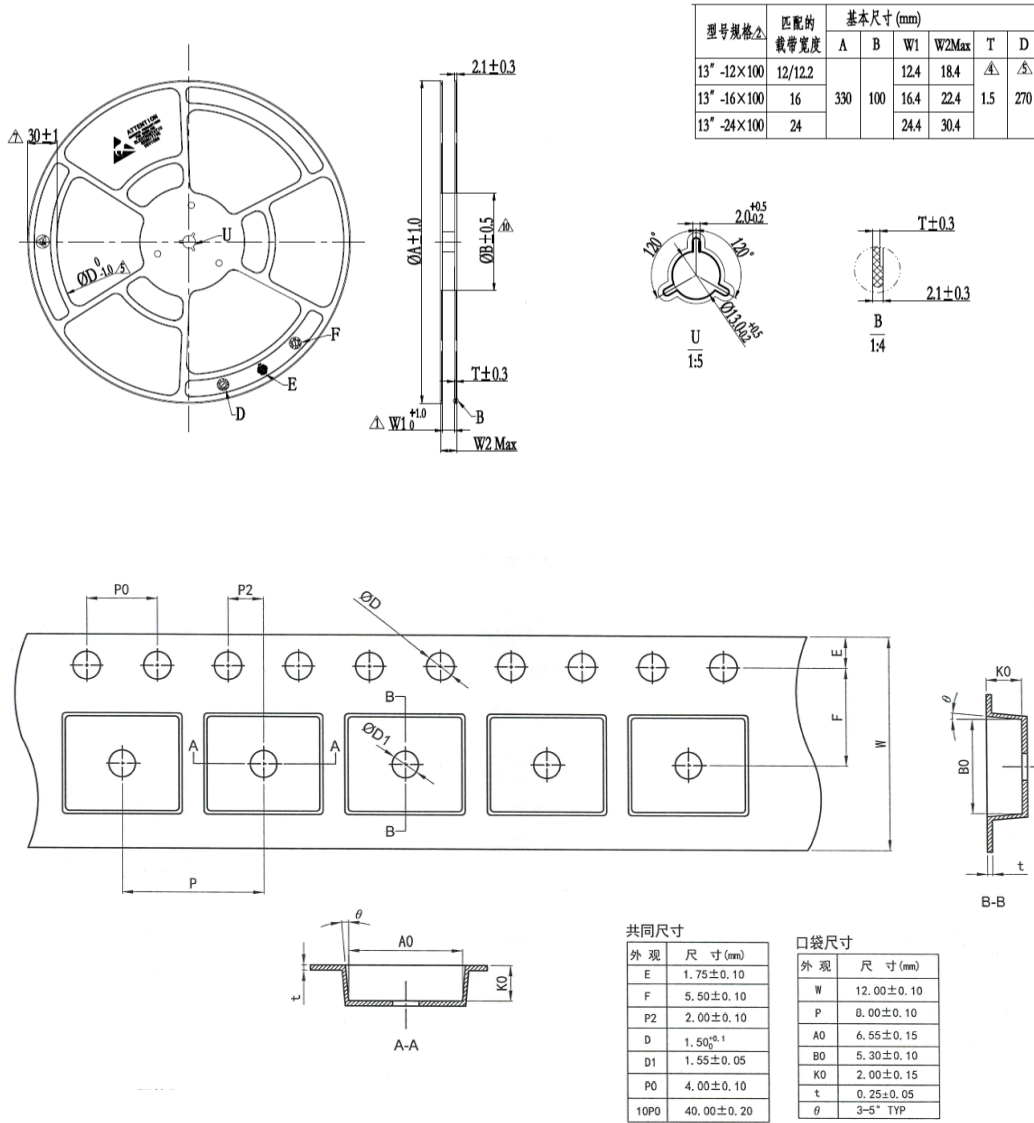

Figure 11.1 Tape and Reel Information of SOP8

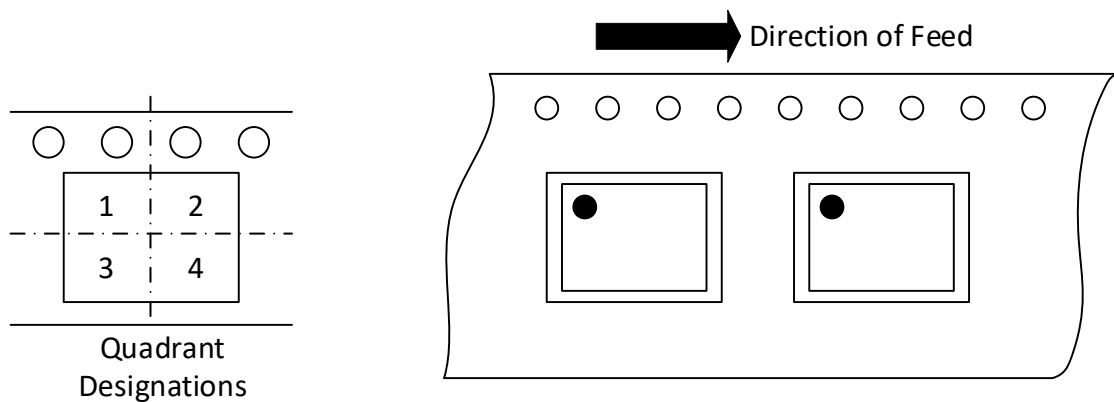
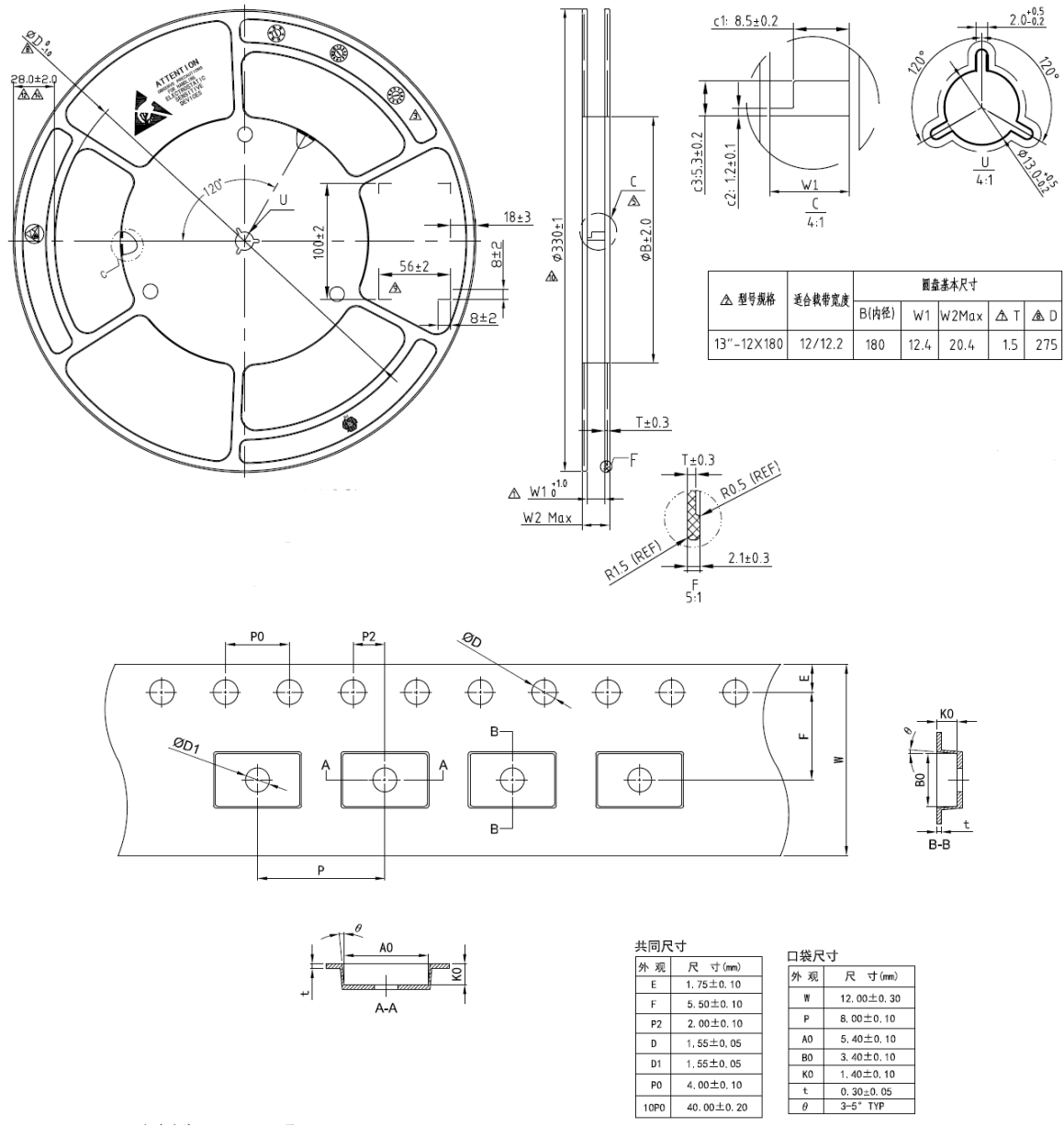

Figure 11.2 Tape and Reel Information of MSOP8

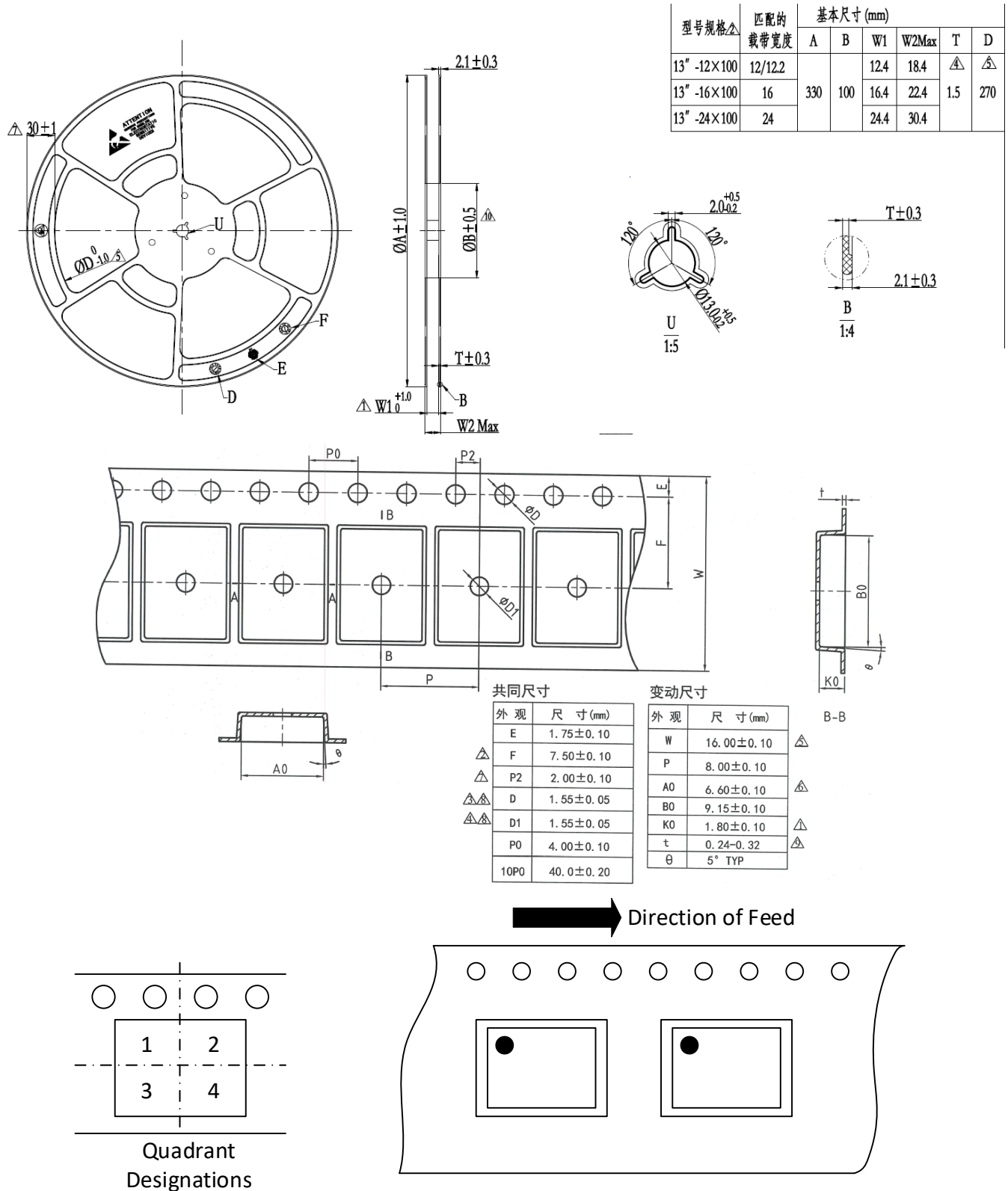

Figure 11.3 Tape and Reel Information of SOP14

12. Revision History

Revision	Description	Date
1.0	Initial Version.	2024/8/15

IMPORTANT NOTICE

The information given in this document shall in no event be regarded as any warranty or authorization of, express or implied, including but not limited to accuracy, completeness, merchantability, fitness for a particular purpose or infringement of any third party's intellectual property rights.

You are solely responsible for your use of Novosense' products and applications, and for the safety thereof. You shall comply with all laws, regulations and requirements related to Novosense's products and applications, although information or support related to any application may still be provided by Novosense.

The resources are intended only for skilled developers designing with Novosense' products. Novosense reserves the rights to make corrections, modifications, enhancements, improvements or other changes to the products and services provided. Novosense authorizes you to use these resources exclusively for the development of relevant applications designed to integrate Novosense's products. Using these resources for any other purpose, or any unauthorized reproduction or display of these resources is strictly prohibited. Novosense shall not be liable for any claims, damages, costs, losses or liabilities arising out of the use of these resources.

For further information on applications, products and technologies, please contact Novosense (www.novosns.com).

Suzhou Novosense Microelectronics Co., Ltd